

EXTENSION OF SUPERCONDUCTING LINAC OPERATION TO LIGHTER BEAMS

Vandana Nanal[#], R.G. Pillay, R. Palit, J. N. Karande, P. Dhumal, M.S. Pose, C. Rozario, S.K. Sarkar, M.E. Sawant, A.N. Takke, S.M. Powale, A.A. Shinde, R.D. Deshpande and S.R. Sinha,

Pelletron Linac Facility, Department of Nuclear and Atomic Physics, TIFR, Mumbai – 400005
S.K. Singh, Ion Accelerator Development Division, BARC, Mumbai – 400085

Abstract

The Pelletron LINAC Facility, Mumbai is a major centre for heavy ion accelerator based research in India. The superconducting linear accelerator, indigenously developed to boost the energy of heavy ion beams delivered by the Pelletron accelerator, has been operational since July, 2007. The Liquid Helium Refrigeration plant for the LINAC has been upgraded to enhance the refrigeration capacity to ~450 Watts at 4.5K without LN₂ pre-cool, from the earlier capacity of ~300 Watts. All beam lines in new user halls have been commissioned and new experimental setups have been added. Several experiments have been carried out using beams of ¹²C, ¹⁶O, ¹⁹F, ²⁸Si, ³¹P. The superconducting lead on Copper QWR cavity used in the LINAC is designed for $\beta=0.1$ and hence it is difficult to accelerate lighter beams. Due to growing interest in studying Li induced reactions on fissile targets at energies higher than 55 MeV, we have recently accelerated ⁷Li beam using four cryostat modules. Starting with 40 MeV ⁷Li beam from the Pelletron, 56 MeV beam was successfully delivered at target station for a test experiment.

INTRODUCTION

The Pelletron LINAC Facility at TIFR, Mumbai, comprising the 14 MV Pelletron (commissioned in 1989) and the superconducting LINAC booster (operational since 2007) [1,2] caters to a variety of experiments in Nuclear Physics, Atomic Physics, Condensed Matter Physics, Material Science, Radiochemistry, Accelerator Mass Spectroscopy, etc. The Pelletron serves both as a standalone accelerator and as an injector to the superconducting LINAC booster. Several modifications have been made to improve the performance of accelerator.

The Liquid Helium Refrigeration plant for the LINAC has been upgraded to enhance the refrigeration capacity to ~450 Watts at 4.5K without LN₂ pre-cool, from the earlier capacity of ~300 Watts. A vacuum jacketed liquid nitrogen transport line from the Low Temperature Facility (LTF) to LINAC accelerator and user halls (~200 m long) has been installed to provide continuous supply of liquid nitrogen.

New micro-controller based instrumentation and interface has been developed for control and monitor of

[#]vnanal@gmail.com

the cryogenic parameters, beam diagnostics and beam transport devices. The operator Graphical User Interface (GUI) in the control room has been suitably enhanced, which communicates with the remote devices via individually addressable 16-port Ethernet to RS232 serial switch [3]. A digital implementation of the Low-Level RF controller based on a self-excited loop (SEL) with phase and amplitude feedback has been developed and successfully tested on a single superconducting cavity [4]. This paper describes some of the recent developments.

CRYOGENICS

The Linac utilizes a custom-built liquid helium refrigerator Linde TCF50S, installed in 1999. It was originally rated for a refrigeration power of 300 Watts at 4.5 K, which could be further enhanced by a maximum of 150 W with LN₂ pre-cool. The two-phase helium at 4.5 K produced at the JT stage in the refrigerator is delivered to the LINAC through a cryogenic distribution system at a supply pressure of 1.6 bara. The phase separation is achieved in the individual cryostat, typically at a pressure of 1.35 bara. The cold helium gas (4.5 K) is returned to the helium refrigerator at a pressure of 1.20 bara. The observed pressure drops in the distribution network and the mass flows have been modelled to estimate the overall thermodynamic efficiency of the system. Due to the elevated delivery pressure of the cryogen to the LINAC, the effective total available cooling power reduces to ~260 Watts. For the whole system without RF power, the estimated heat load is ~140 W. Therefore, the net available cooling power for RF load is only ~120 W, which is not adequate to power up all the accelerating cavities. Hence, during the accelerator operation, the refrigerator was used with partial liquid nitrogen pre-cooling. In order to eliminate the use of liquid Nitrogen pre-cooling, the plant has been upgraded to deliver ~450 W at 4.5 K. This has been done by replacing the original compressor having a flow rate of 62g/s by a new one having a capacity of 79g/s. Also, two turbines in the cold box have been replaced by more efficient versions and all the valve seats in the plant were changed to adapt to the higher mass flow rate. The upgraded plant has been fully tested and commissioned. The cryogenic system was found to be very stable during the accelerator operation with full RF load. The helium gas recovery system has been augmented with an additional recovery compressor and a 30 m³ gas bag, to provide to total capacity of 60 m³. This is expected to significantly reduce the helium gas

losses in case of sudden power failures during LINAC operation.

The liquid Nitrogen required for shield cooling in the LINAC distribution and module cryostats as well as user requirements are fully met by the LTF, TIFR. To facilitate ease of operations, a vacuum jacketed liquid nitrogen transport line from the LTF to the LINAC accelerator and user halls (~200m long) has been installed to provide a continuous supply of liquid nitrogen.

INSTRUMENTATION & CONTROL SYSTEM

As a part of an ongoing effort, the interface and control electronics have been upgraded for various accelerator subsystems. In particular, new micro-controller based instrumentation has been developed for cryogenic parameters, beam diagnostics and beam transport devices.

A CAMAC based accelerator control system based on a master-slave configuration has been developed using JAVA operating on Linux OS [3]. The operator GUI deployed on the Master Control Station (MCS) in the accelerator control room is designed to communicate with individual devices. All power supplies for the beam transport elements like magnetic steerers, quadrupoles and dipoles are controlled from the MCS via individually addressable 16-port Ethernet to RS232 serial switch. Several other devices like Faraday Cups, BPMs, Cryogenic controls etc. are also connected via serial to Ethernet switches in a similar manner.

On selection of a particular Faraday Cup, the measured beam current is displayed on an on-screen panel meter with suitable auto-scaling. Similarly, up to two BPMs can be simultaneously selected on the GUI and displayed on a multi-channel oscilloscope. The updated control system allows simultaneous setting up and monitoring of parameters for the different LINAC subsystems. The system is operator friendly, stable and very reliable.

We have developed a digital implementation of the Low-Level RF controller based on a self-excited loop (SEL) with phase and amplitude feedback. The digital LLRF controller is expected to be inherently free of certain limitations like: DC off-sets, drifts, gain imbalance, impedance mismatch, etc besides having the flexibility and ability to execute complex algorithms. Figure 1 shows a schematic view of digital RF control architecture. The digital control card has been successfully tested on a single superconducting cavity [1,4].

In addition, a two channel BPM digitizer and FPGA based CAMAC ADC, DAC cards have been developed. These cards have been designed in a modular fashion to

enable ease of trouble shooting and maintenance. These cards are installed in the Pelletron control system.

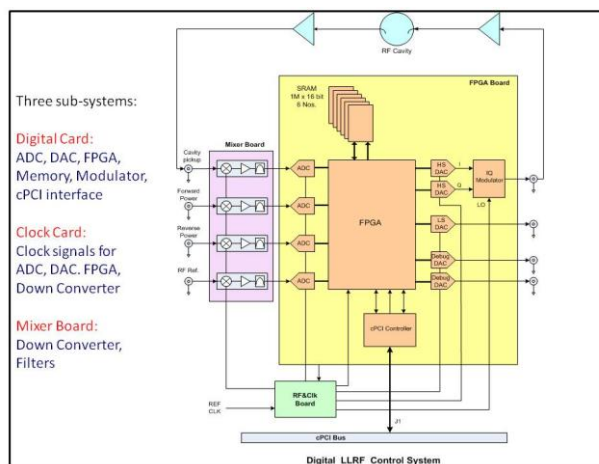

Figure 1: A Schematic of digital RF control architecture

ACCELERATOR OPERATION

All beam lines in new user halls have been commissioned and several new experimental setups have been added. Figure 2 shows a schematic layout of the LINAC and user halls. Table 1 gives a summary of various beams and energies delivered for user experiments. Typical beam transmission from LINAC entry to exit is found to be 80-85%. The available beam current on target after collimators is 1-5 pA with very good timing, $\sigma \sim 0.3$ ns.

Table 1: Beams accelerated through LINAC

Beam	E_{pell} (MeV)	E_{LINAC} (MeV)	E_{total} (MeV)
^{12}C	70-82	28-38	100-120
^{16}O	80-94	22-55	110-135
^{19}F	80-94	45-55	135-145
^{28}Si	90-100	45-109	135-209
^{31}P	95-111	30-94	125-207

The superconducting lead on Copper QWR cavity is designed for $\beta=0.1$ and hence it is difficult to accelerate lighter beams. Due to growing interest in studying Li induced reactions on fissile targets at energies higher than 55 MeV, we have recently accelerated ^7Li beam using four cryostat modules. The $^7\text{Li}^{3+}$ beam of 42 MeV from the Pelletron was accelerated to 56.8 MeV using 16 resonators. Time spectra measured with 1" BaF2 at LINAC I entry (top panel) and after the mid-bend at LINAC II entry (bottom panel) are shown in Figure 3. Nearly same time structure of beam at lin4 diagnostic station ensured good acceptance in LINAC II. The measured time spread " σ " is inclusive of detector resolution.

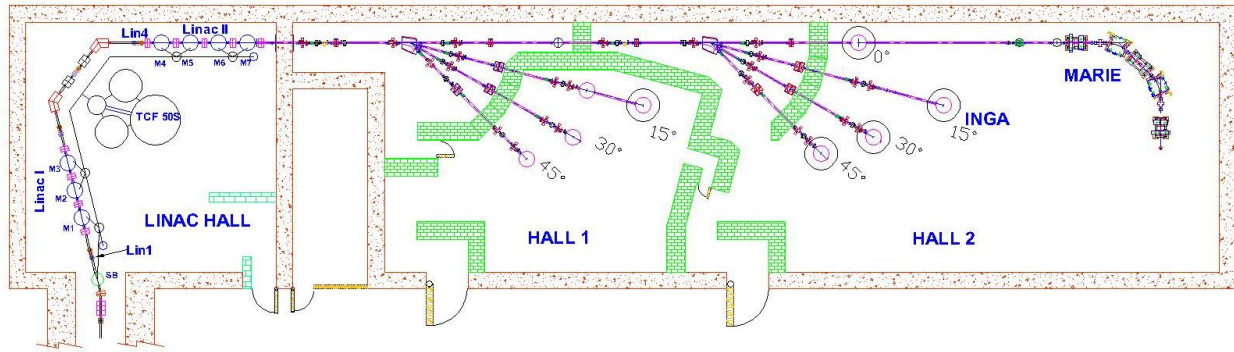

Figure 2: A Schematic layout of Linac and user halls

A test experiment with this accelerated beam, namely, ${}^7\text{Li}$ ($E \sim 45$ to 55.6 MeV) + ${}^{232}\text{Th}$ (~ 3 mg/cm²) was carried out to study the yields of fusion evaporation residues and fission fragments using Indian National Gamma Array (INGA). A total of 18 Compton suppressed Clover detectors were used to measure the prompt gamma rays from the excited nuclei produced in the reaction and detailed analysis is in progress [5].

SUMMARY

The Pelletron LINAC facility is regularly operated for a variety of experiments. The cryogenics system of the LINAC has been upgraded for the enhanced capacity, such that the full LINAC can be operated without LN₂ precool. Starting with 40 MeV ${}^7\text{Li}$ beam from the Pelletron, 56 MeV beam was successfully delivered at target station for a test experiment. We also plan to upgrade the Pelletron and associated subsystems, in order to extend operations of LINAC to heavier beams. Design of low beta, high performance niobium superconducting half wave resonator (HWR) with $\beta_0 = 0.05$ is in progress. The development of digital RF controller cards is being planned for better performance. Instrumentation and interface for control and monitor of various accelerator subsystems is continuously being upgraded for ease of operations and performance.

ACKNOWLEDGEMENT

We would like to thank the Pelletron-LINAC staff, DNAP, Low Temperature Facility, Central Workshop and Electronics Division (BARC) for their support.

REFERENCES

- [1] R.G. Pillay, "Overview of the Pelletron Linac Facility", InPAC2011 proceedings.
- [2] V. Nanal *et al.*, "Operational experience of superconducting Linac booster at Mumbai", <http://accelconf.web.cern.ch/AccelConf/HIAT2009/papers/th-07.pdf>; HIAT09, Venice (Italy) 2009.
- [3] S.K. Singh *et al.*, InPAC2011 proceedings.
- [4] G. Joshi *et al.* "Development of the Model of a Self-Excited Loop", <http://accelconf.web.cern.ch/AccelConf/PAC2009/papers/we3rac06.pdf>; PAC09, Vancouver (Canada), 2009.
- [5] R. Palit *et al.*, to be published.

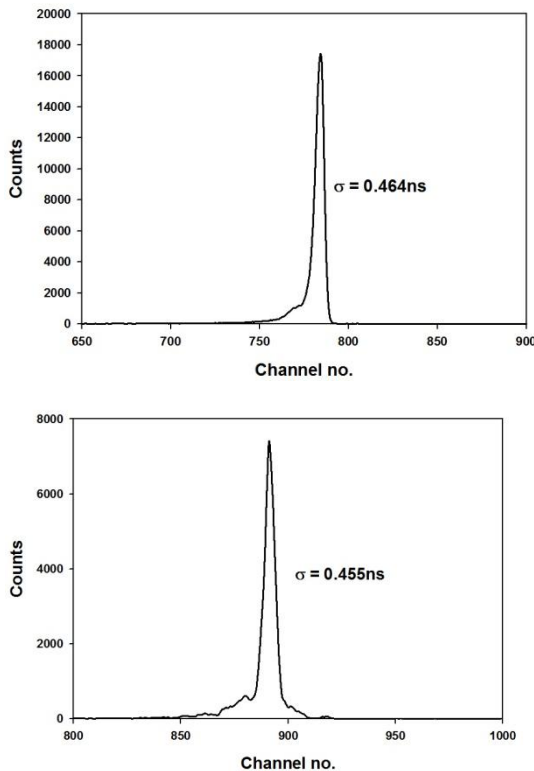

Figure 3: Beam Timing spectra for ${}^7\text{Li}$ measured at the entrance of LINAC I (top panel) and LINAC II (bottom panel). The measured σ is inclusive of detector resolution.