

# Introduction to Superheavy Elements

Cody Folden

Cyclotron Institute, Texas A&M University

Exotic Beam Summer School

July 28, 2017

# Outline

- The Elements as They Stand Today
- Nuclear Reactions Used to Make the Heaviest Elements
- The Future of New Elements and the Use of Exotic Beams
- Recent Results in Chemical and Atomic Physics Experiments
- How are the Experiments Performed?
- The Frontier of Chemical Experiments

# The Elements as They Stand Today

- There are 92 naturally occurring elements (but it depends on how you count them).
  - The heaviest element that occurs in large quantity is uranium (atomic number 92). You can mine it like gold.
  - Technetium (atomic number 43) does not occur naturally.
  - Promethium (atomic number 61) does not occur naturally.
  - $^{237}\text{Np}$  and  $^{239}\text{Pu}$  have been discovered in natural ores. They are produced by naturally occurring nuclear reactions.
  - $^{244}\text{Pu}$  has also been discovered in nature! This isotope has a half-life of “only” 80 million years.
- The artificial elements bring the total to 118.

# The Periodic Table

atomic number      atomic weight

14    28.09

**Si**

Silicon

symbol:  
black solid  
blue liquid  
red gas

name

- alkali metals
- alkaline earth metals
- transitional metals
- other metals
- non metals
- noble gases

1 1.01 <b>H</b> Hydrogen																	2 4.003 <b>He</b> Helium						
3 6.94 <b>Li</b> Lithium	4 9.01 <b>Be</b> Beryllium																	5 10.81 <b>B</b> Boron	6 12.01 <b>C</b> Carbon	7 14.01 <b>N</b> Nitrogen	8 15.999 <b>O</b> Oxygen	9 18.998 <b>F</b> Fluorine	10 20.18 <b>Ne</b> Neon
11 22.99 <b>Na</b> Sodium	12 24.31 <b>Mg</b> Magnesium																	13 26.98 <b>Al</b> Aluminum	14 28.09 <b>Si</b> Silicon	15 30.97 <b>P</b> Phosphorus	16 32.06 <b>S</b> Sulfur	17 35.45 <b>Cl</b> Chlorine	18 39.95 <b>Ar</b> Argon
19 39.10 <b>K</b> Potassium	20 40.08 <b>Ca</b> Calcium	21 44.96 <b>Sc</b> Scandium	22 47.90 <b>Ti</b> Titanium	23 50.94 <b>V</b> Vanadium	24 51.996 <b>Cr</b> Chromium	25 54.94 <b>Mn</b> Manganese	26 55.85 <b>Fe</b> Iron	27 58.93 <b>Co</b> Cobalt	28 58.70 <b>Ni</b> Nickel	29 63.55 <b>Cu</b> Copper	30 65.37 <b>Zn</b> Zinc	31 69.72 <b>Ga</b> Gallium	32 72.59 <b>Ge</b> Germanium	33 74.92 <b>As</b> Arsenic	34 78.96 <b>Se</b> Selenium	35 79.90 <b>Br</b> Bromine	36 83.80 <b>Kr</b> Krypton						
37 85.47 <b>Rb</b> Rubidium	38 87.62 <b>Sr</b> Strontium	39 88.91 <b>Y</b> Yttrium	40 91.22 <b>Zr</b> Zirconium	41 92.91 <b>Nb</b> Niobium	42 95.94 <b>Mo</b> Molybdenum	43 (98) <b>Tc</b> Technetium	44 101.07 <b>Ru</b> Ruthenium	45 102.91 <b>Rh</b> Rhodium	46 106.40 <b>Pd</b> Palladium	47 107.87 <b>Ag</b> Silver	48 112.41 <b>Cd</b> Cadmium	49 114.82 <b>In</b> Indium	50 118.69 <b>Sn</b> Tin	51 121.75 <b>Sb</b> Antimony	52 127.60 <b>Te</b> Tellurium	53 126.90 <b>I</b> Iodine	54 131.30 <b>Xe</b> Xenon						
55 132.91 <b>Cs</b> Cesium	56 137.33 <b>Ba</b> Barium	57 138.91 <b>La</b> Lanthanum	72 178.49 <b>Hf</b> Hafnium	73 180.95 <b>Ta</b> Tantalum	74 183.85 <b>W</b> Tungsten	75 186.21 <b>Re</b> Rhenium	76 190.20 <b>Os</b> Osmium	77 192.22 <b>Ir</b> Iridium	78 195.09 <b>Pt</b> Platinum	79 196.97 <b>Au</b> Gold	80 200.59 <b>Hg</b> Mercury	81 204.37 <b>Tl</b> Thallium	82 207.19 <b>Pb</b> Lead	83 208.98 <b>Bi</b> Bismuth	84 (209) <b>Po</b> Polonium	85 (210) <b>At</b> Astatine	86 (222) <b>Rn</b> Radon						
87 (223) <b>Fr</b> Francium	88 226.03 <b>Ra</b> Radium	89 227.03 <b>Ac</b> Actinium	104 (261) <b>Rf</b> Rutherfordium	105 (262) <b>Db</b> Dubnium	106 (266) <b>Sg</b> Seaborgium	107 (262) <b>Bh</b> Bohrium	108 (265) <b>Hs</b> Hassium	109 (266) <b>Mt</b> Meitnerium	110 (271) <b>Ds</b> Darmstadtium	111 (272) <b>Rg</b> Roentgenium	112 (277) <b>Cn</b> Copernicium	113 (278) <b>Nh</b> Nihonium	114 (288) <b>Fl</b> Flerovium	115 (288) <b>Mc</b> Moscovium	116 (292) <b>Lv</b> Livermorium	117 (293) <b>Ts</b> Tennessine	118 (294) <b>Og</b> Oganesson						
(119)	(120)	(121)	(154)																				

The heaviest elements are all produced *artificially*!

Lanthanides ▶	58 140.12 <b>Ce</b> Cerium	59 140.91 <b>Pr</b> Praseodymium	60 144.24 <b>Nd</b> Neodymium	61 (145) <b>Pm</b> Promethium	62 150.40 <b>Sm</b> Samarium	63 151.96 <b>Eu</b> Europium	64 157.25 <b>Gd</b> Gadolinium	65 158.93 <b>Tb</b> Terbium	66 162.50 <b>Dy</b> Dysprosium	67 164.93 <b>Ho</b> Holmium	68 167.26 <b>Er</b> Erbium	69 168.93 <b>Tm</b> Thulium	70 173.04 <b>Yb</b> Ytterbium	71 174.97 <b>Lu</b> Lutetium
Actinides ▶	90 232.04 <b>Th</b> Thorium	91 231.04 <b>Pa</b> Protactinium	92 238.03 <b>U</b> Uranium	93 237.05 <b>Np</b> Neptunium	94 (244) <b>Pu</b> Plutonium	95 (243) <b>Am</b> Americium	96 (247) <b>Cm</b> Curium	97 (247) <b>Bk</b> Berkelium	98 (251) <b>Cf</b> Californium	99 (252) <b>Es</b> Einsteinium	100 (257) <b>Fm</b> Fermium	101 (260) <b>Md</b> Mendelevium	102 (259) <b>No</b> Nobelium	103 (262) <b>Lr</b> Lawrencium

Superactinides ▶▶ (122-153)

# Why Study Heavy Elements?

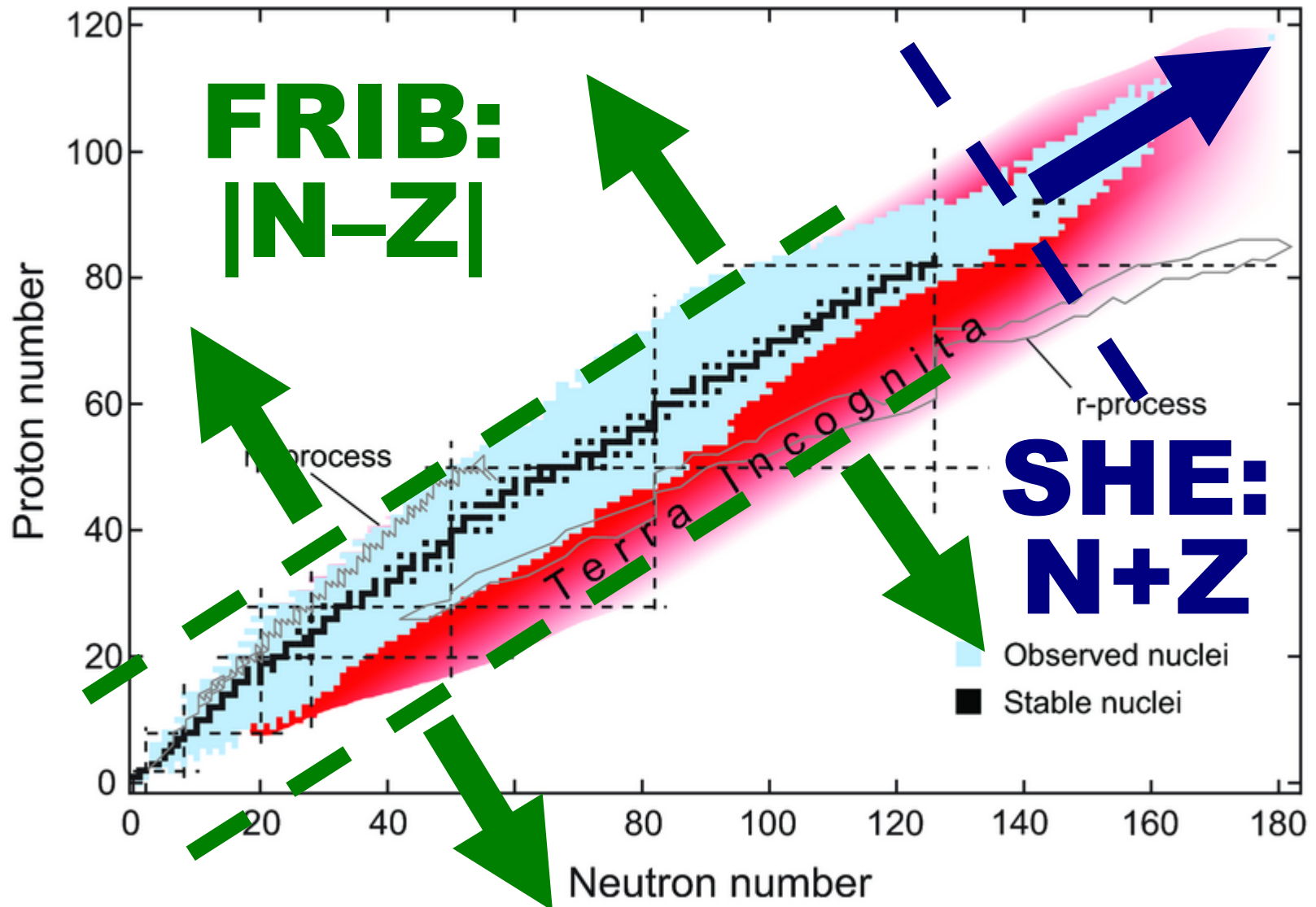

# Criteria for a New Element

- Must exist for approximately  $10^{-14}$  s. This is roughly the time needed for a nucleus to collect a cloud of electrons.
- The atomic number must be different from all known atomic numbers, beyond a reasonable doubt. It does *not* have to actually be determined, though.
- The same goes for the mass number.
- Physical or chemical methods can be used.
- Confirmatory experiments are preferred.
- Giving it a name immediately is discouraged.
- In reality, these criteria have not stopped arguments about who discovered what. They can last for years.

# New Element Discoveries ca. 1980-2010

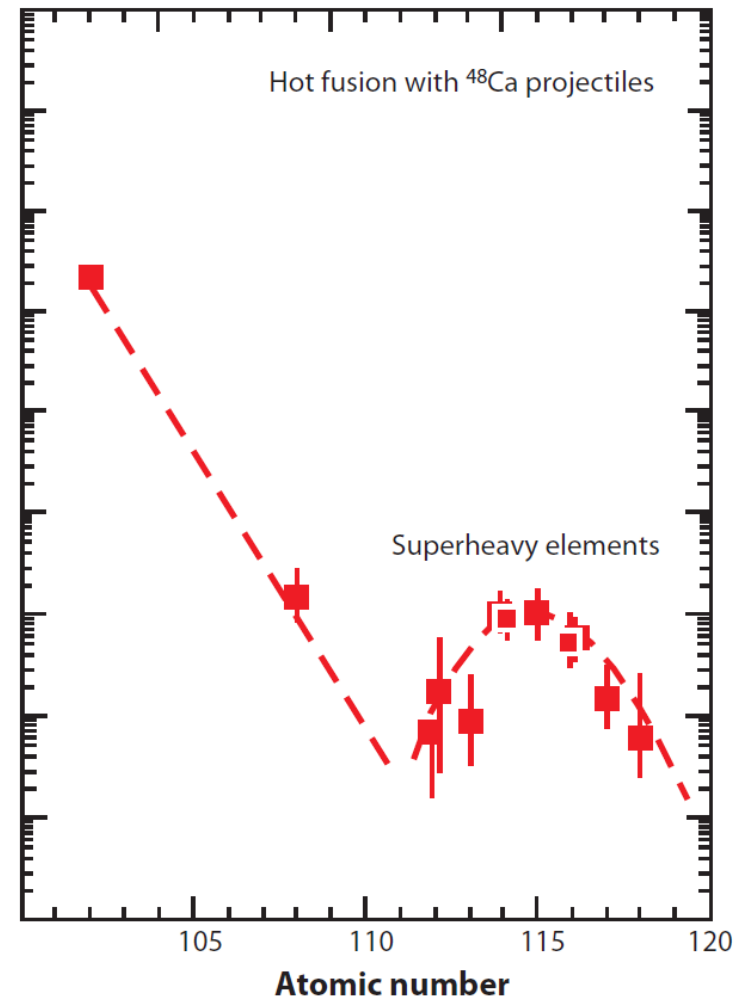
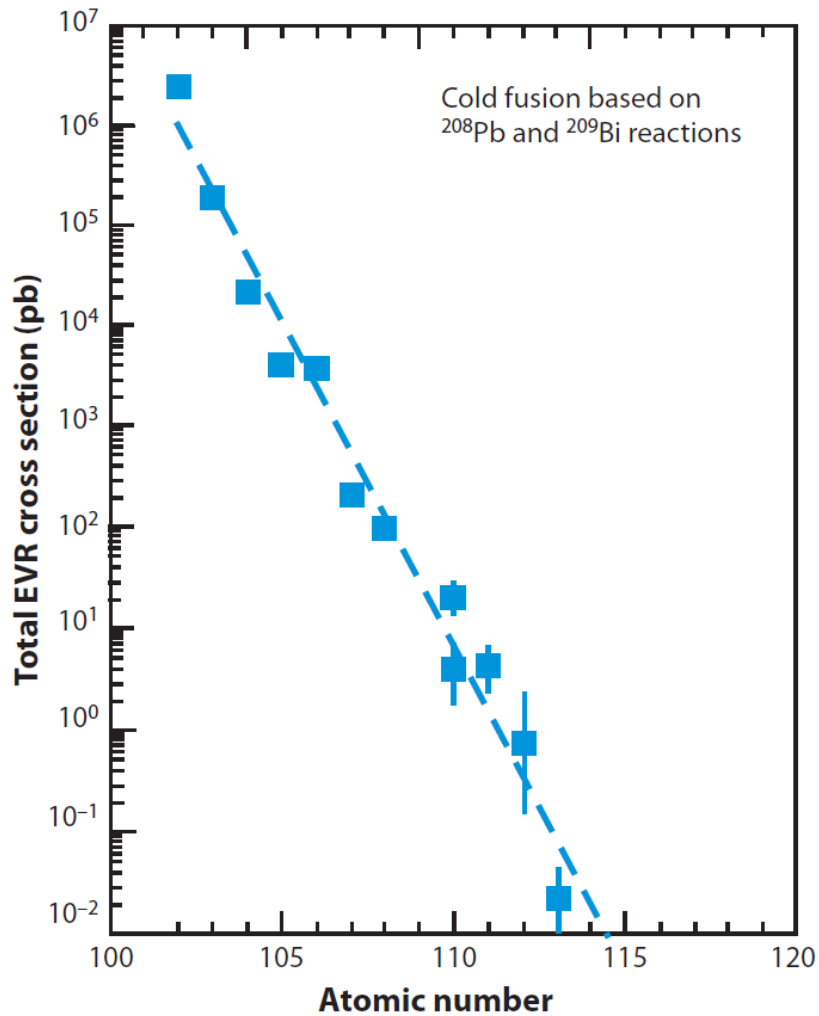

# Let's Study the "Literature"

- $^{250}\text{Md} + ^{40}\text{K} \rightarrow ^{290}_{120}$
- $^{244}\text{Pu} + ^{58}\text{Fe} \rightarrow ^{302}_{120}$
- $^{248}\text{Cm} + ^{54}\text{Cr} \rightarrow ^{302}_{120}$
- $^{238}\text{U} + ^{\text{nat}}\text{Ni} \rightarrow ?_{120}$
- Some of these reactions have been studied!
- The  $^{250}\text{Md}$  reaction is impossible, though, because its half-life is too short (52 s).

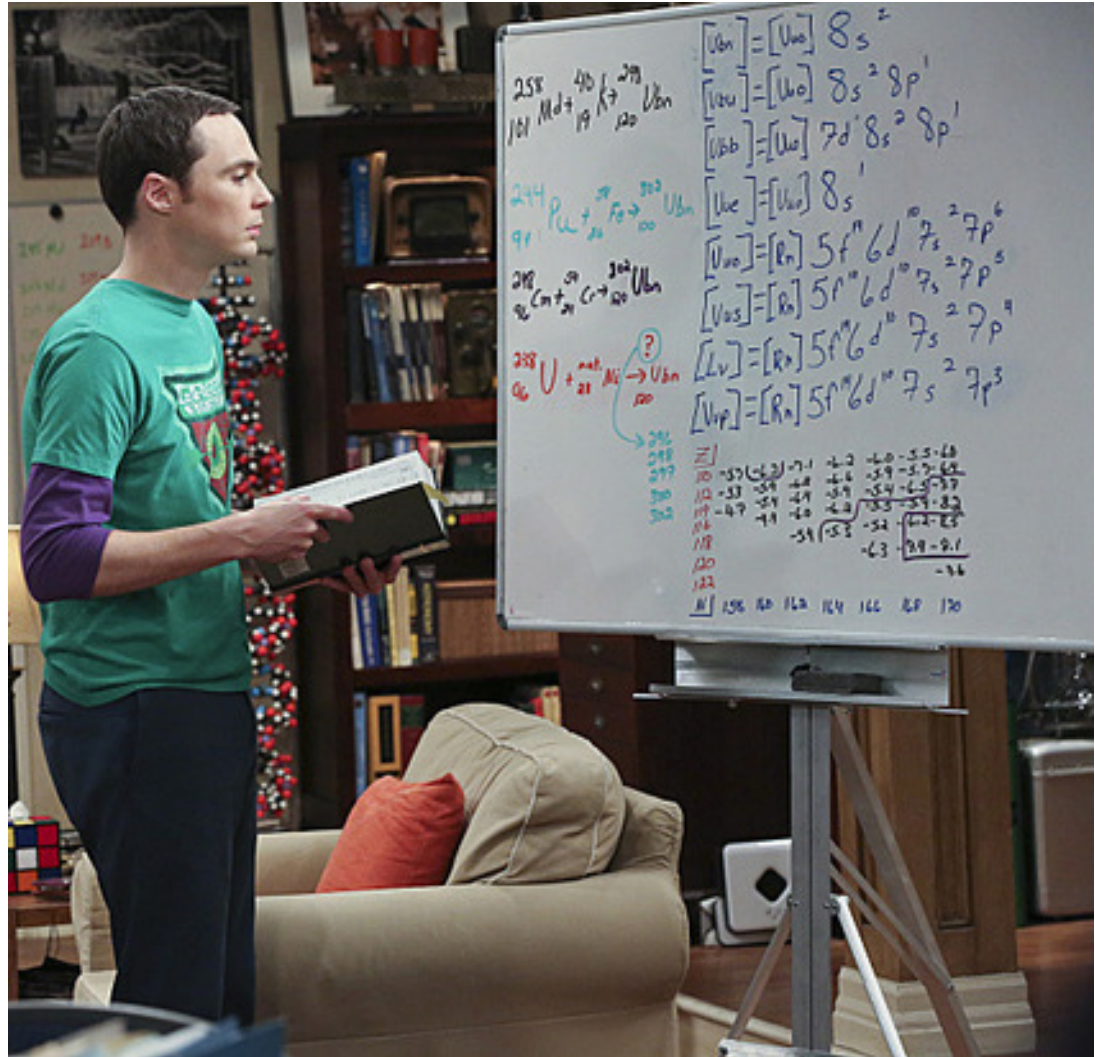

*The Big Bang Theory*, S7E6. Slide inspired by Ch. E. Düllmann.



# Current and Future History of Elements Above 118

- The problem: Targets above Cf are not available.

Lanthanides ▶	58 140.12 <b>Ce</b> Cerium	59 140.91 <b>Pr</b> Praseodymium	60 144.24 <b>Nd</b> Neodymium	61 (145) <b>Pm</b> Promethium	62 150.40 <b>Sm</b> Samarium	63 151.96 <b>Eu</b> Europium	64 157.25 <b>Gd</b> Gadolinium	65 158.93 <b>Tb</b> Terbium	66 162.50 <b>Dy</b> Dysprosium	67 164.93 <b>Ho</b> Holmium	68 167.26 <b>Er</b> Erbium	69 168.93 <b>Tm</b> Thulium	70 173.04 <b>Yb</b> Ytterbium	71 174.97 <b>Lu</b> Lutetium
Actinides ▶	90 232.04 <b>Th</b> Thorium	91 231.04 <b>Pa</b> Protactinium	92 238.03 <b>U</b> Uranium	93 237.05 <b>Np</b> Neptunium	94 (244) <b>Pu</b> Plutonium	95 (243) <b>Am</b> Americium	96 (247) <b>Cm</b> Curium	97 (247) <b>Bk</b> Berkelium	98 (251) <b>Cf</b> Californium	99 (252) <b>Es</b> Einsteinium	100 (257) <b>Fm</b> Fermium	101 (260) <b>Md</b> Mendelevium	102 (259) <b>No</b> Nobelium	103 (262) <b>Lr</b> Lawrencium

- A number of reactions have been studied using projectiles heavier than  $^{48}\text{Ca}$ , but none have succeeded:
  - $^{58}\text{Fe} + ^{244}\text{Pu} \rightarrow ^{298}_{120} + 4n$
  - $^{54}\text{Cr} + ^{248}\text{Cm} \rightarrow ^{298}_{120} + 4n$
  - $^{50}\text{Ti} + ^{249}\text{Cf} \rightarrow ^{295}_{120} + 4n$
  - $^{50}\text{Ti} + ^{249}\text{Bk} \rightarrow ^{295}_{119} + 4n$
  - $^{64}\text{Ni} + ^{238}\text{U} \rightarrow ^{298}_{120} + 4n$
- The great question is, “What reaction is most likely to lead to the discovery of the next new element?”

# Current and Future History of Elements Above 118

- JINR-LLNL studied the  $^{58}\text{Fe} + ^{244}\text{Pu} \rightarrow ^{298}_{120} + 4n$  reaction and reported an upper limit cross section of 0.4 pb (0.74 pb at 84% confidence).
- GSI Experiments:
  - $^{54}\text{Cr} + ^{248}\text{Cm} \rightarrow ^{298}_{120} + 4n$ ,  $\sigma < 0.58$  pb (1.92 pb at 84%)
    - Compare with  $^{48}\text{Ca} + ^{248}\text{Cm} \rightarrow ^{292}\text{Lv} + 4n$ :  $\sigma_{\text{EVR}} \approx 3.3$  pb
  - $^{50}\text{Ti} + ^{249}\text{Cf} \rightarrow ^{295}_{120} + 4n$ 
    - Compare with  $^{48}\text{Ca} + ^{249}\text{Cf} \rightarrow ^{294}\text{Og} + 3n$ :  $\sigma_{\text{EVR}} \approx 0.5$  pb
  - $^{50}\text{Ti} + ^{249}\text{Bk} \rightarrow ^{295}_{119} + 4n$ ,  $\sigma < 0.052$  pb
    - Compare with  $^{48}\text{Ca} + ^{249}\text{Bk} \rightarrow ^{293}\text{Ts} + 4n$ :  $\sigma_{\text{EVR}} \approx 1.3$  pb
  - $^{64}\text{Ni} + ^{238}\text{U} \rightarrow ^{298}_{120} + 4n$ :  $\sigma < 0.09$  pb
- $^{50}\text{Ti} + ^{252}\text{Cf} \rightarrow ^{298}_{120} + 4n$  has also been proposed.

# How does the nuclear reaction work?

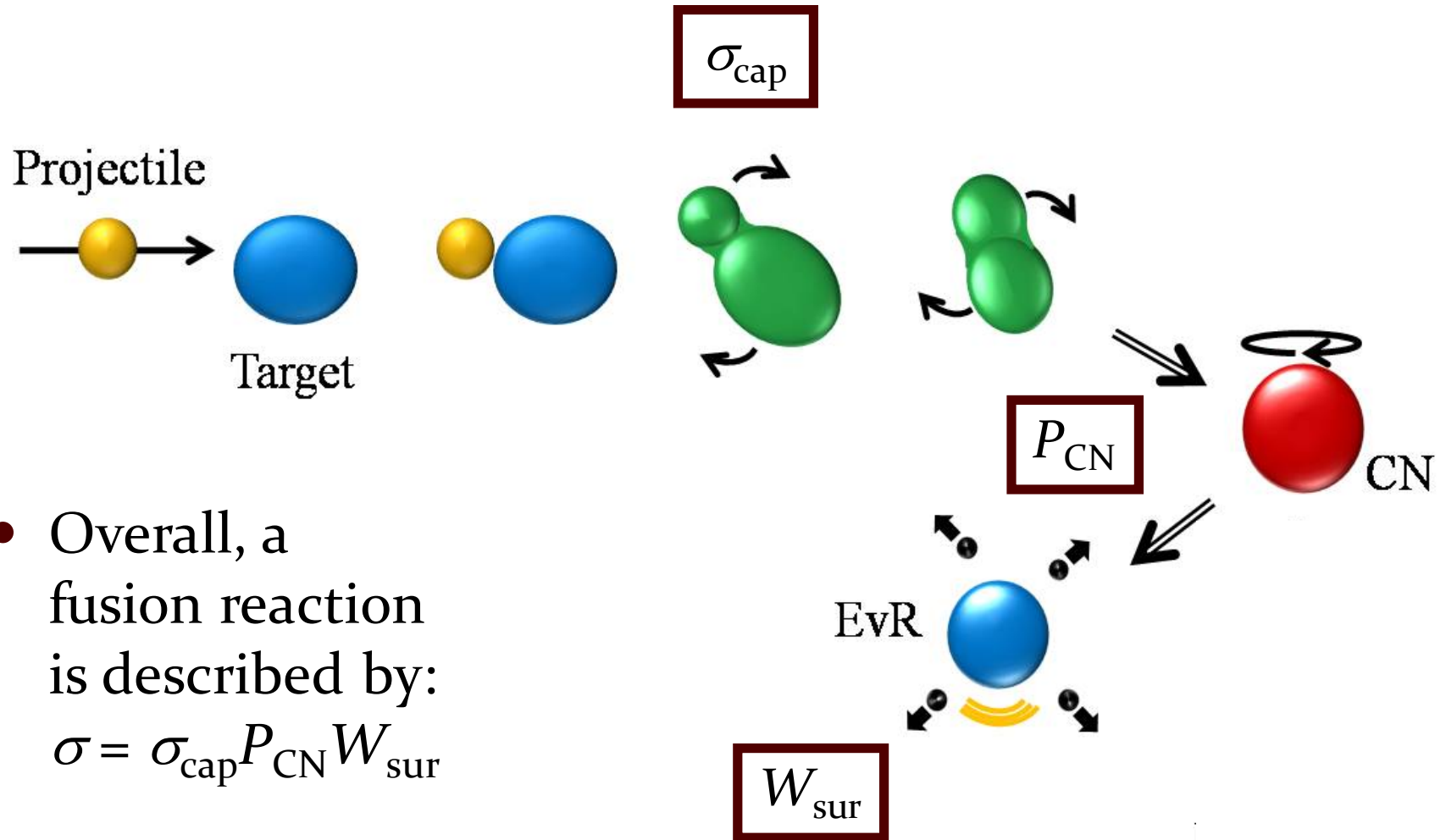

- Overall, a fusion reaction is described by:

$$\sigma = \sigma_{\text{cap}} P_{\text{CN}} W_{\text{sur}}$$

# The Fission Barrier

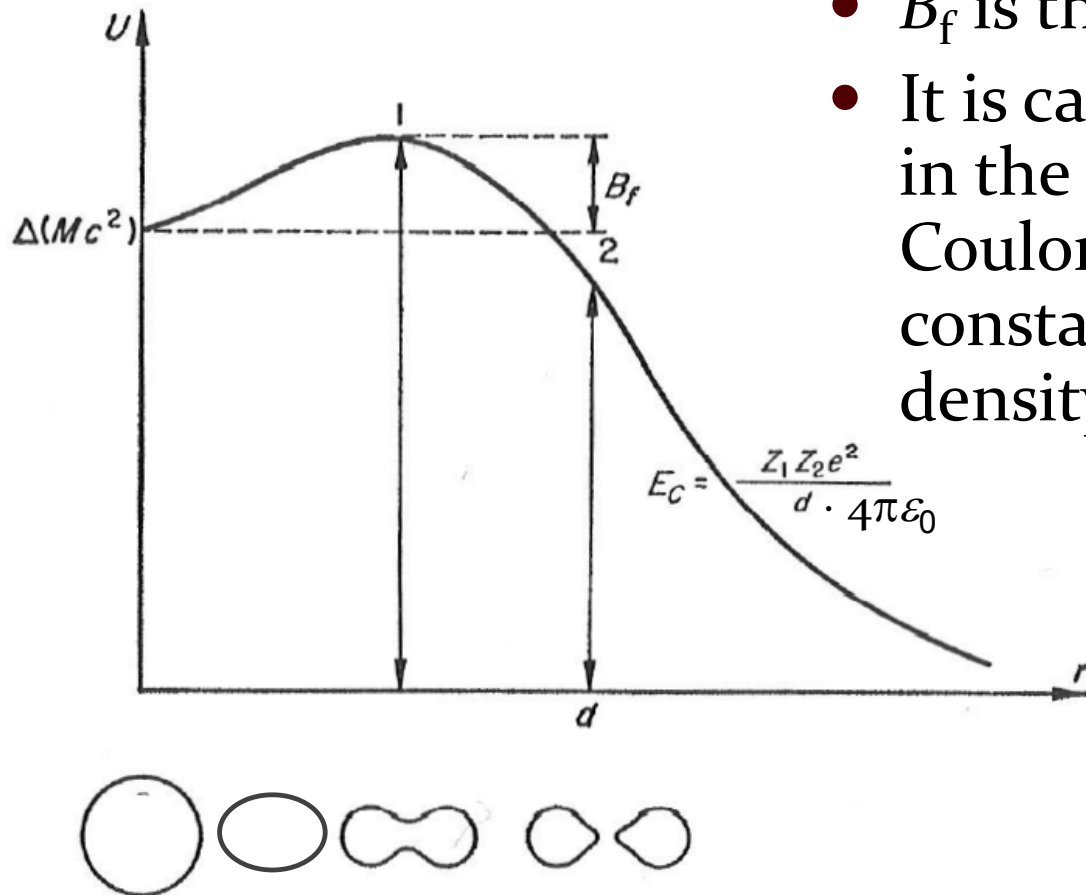

- $B_f$  is the *fission barrier*.
- It is caused by a change in the surface and Coulomb energies at constant volume and density.

Fig. 7.3 Diagram showing potential energy as a function of deformation from a spherical nucleus. (1) Point of critical deformation (saddlepoint); (2) Point of scission.

# Shell Effects in SHE Production

- A larger shell effect can result in a higher fission barrier. This has had a dramatic impact on our ability to produce SHEs.

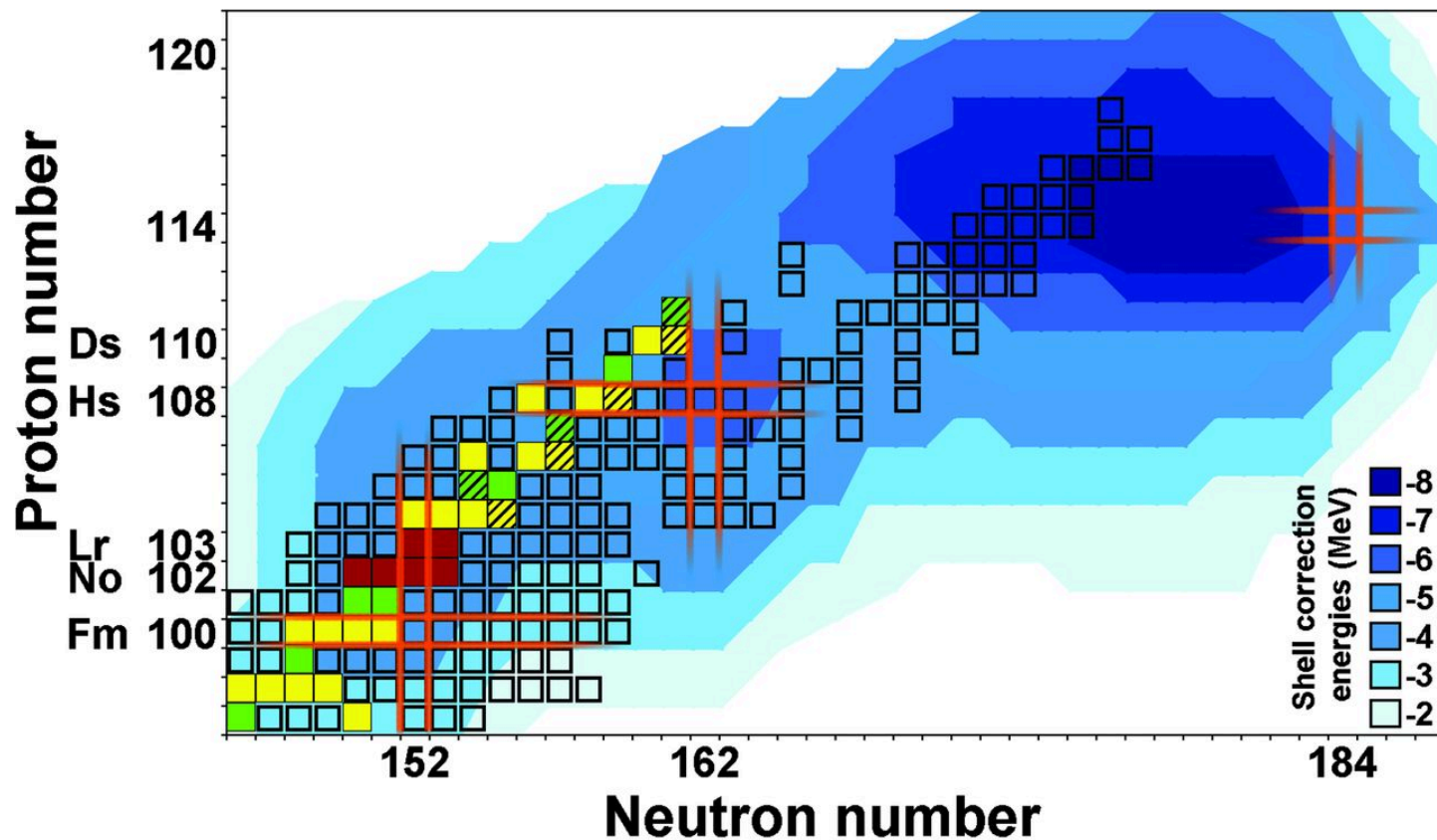

# How do you make a heavy nucleus?

- The production of a heavy nucleus is a competition between neutron emission and fission.
- The evaporation residue cross section can be written as:

$$\sigma = \sigma_{\text{cap}} P_{\text{CN}} W_{\text{sur}}(E^*, l)$$

$$= \sigma_{\text{cap}} P_{\text{CN}} \prod_{i=1}^x (\Gamma_n / \Gamma_{\text{tot}})_i$$

$$\approx \sigma_{\text{cap}} P_{\text{CN}} \prod_{i=1}^x (\Gamma_n / \Gamma_f)_i$$

$$\Gamma_n / \Gamma_f \propto \exp[-(S_n - B_f) / T]$$

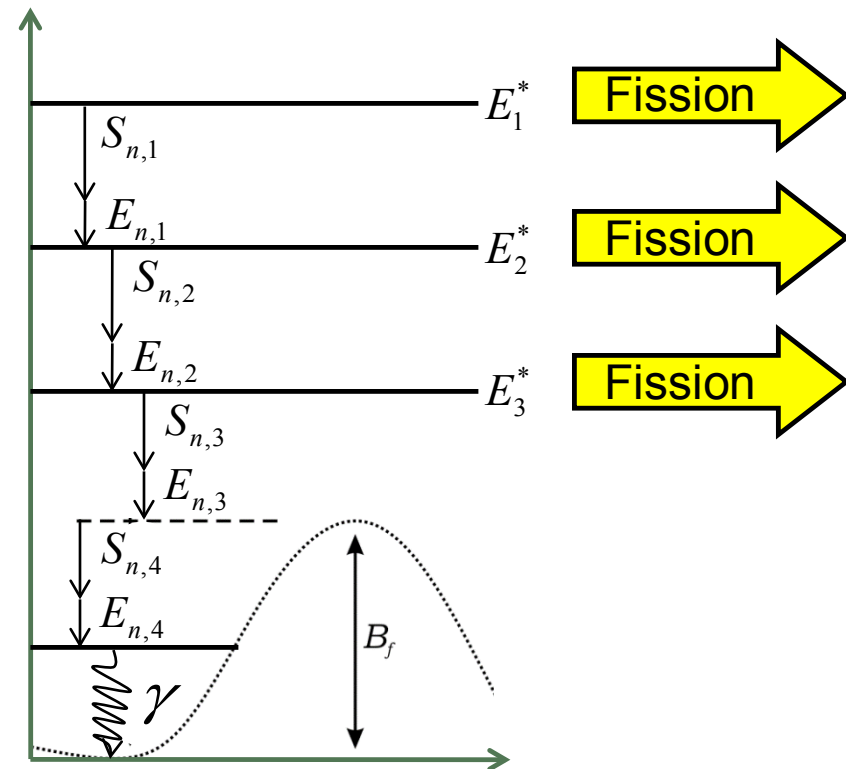

# Survival of the Compound Nucleus

- This influence of  $B_f - B_n$  is significant:

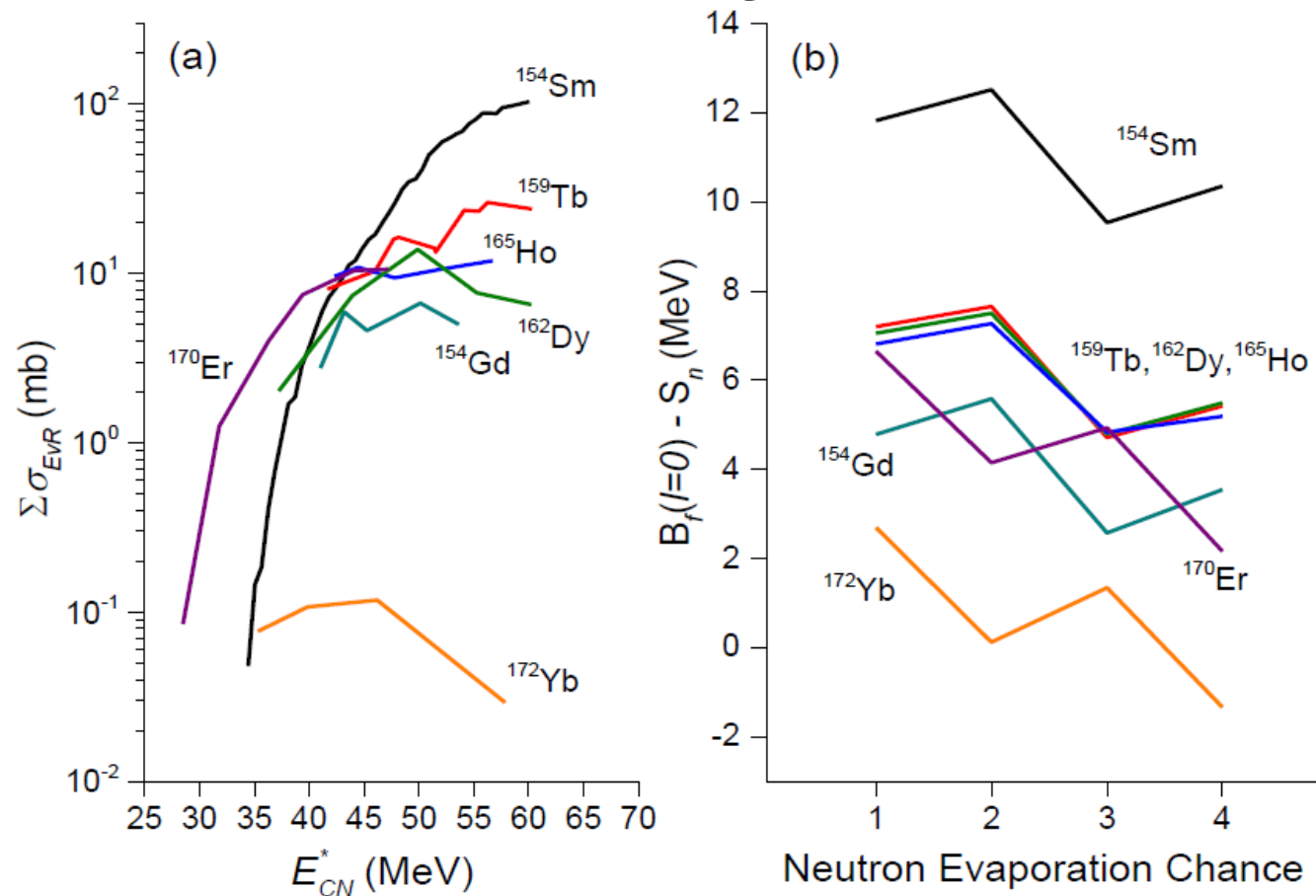

D. A. Mayorov *et al.*, PRC **90**, 024602 (2015); A. M. Stefanini *et al.*, EPJA **23**, 473 (2005).  
R. N. Sagaidak *et al.*, PRC **68**, 014603 (2003); C. C. Sahm *et al.*, Nucl. Phys. A **441**, 316 (1985).

# Dependence of $B_f - S_n$ on Model

- The model in use has a dramatic impact on  $B_f - S_n$ .
- This has a dramatic impact on calculated cross sections.

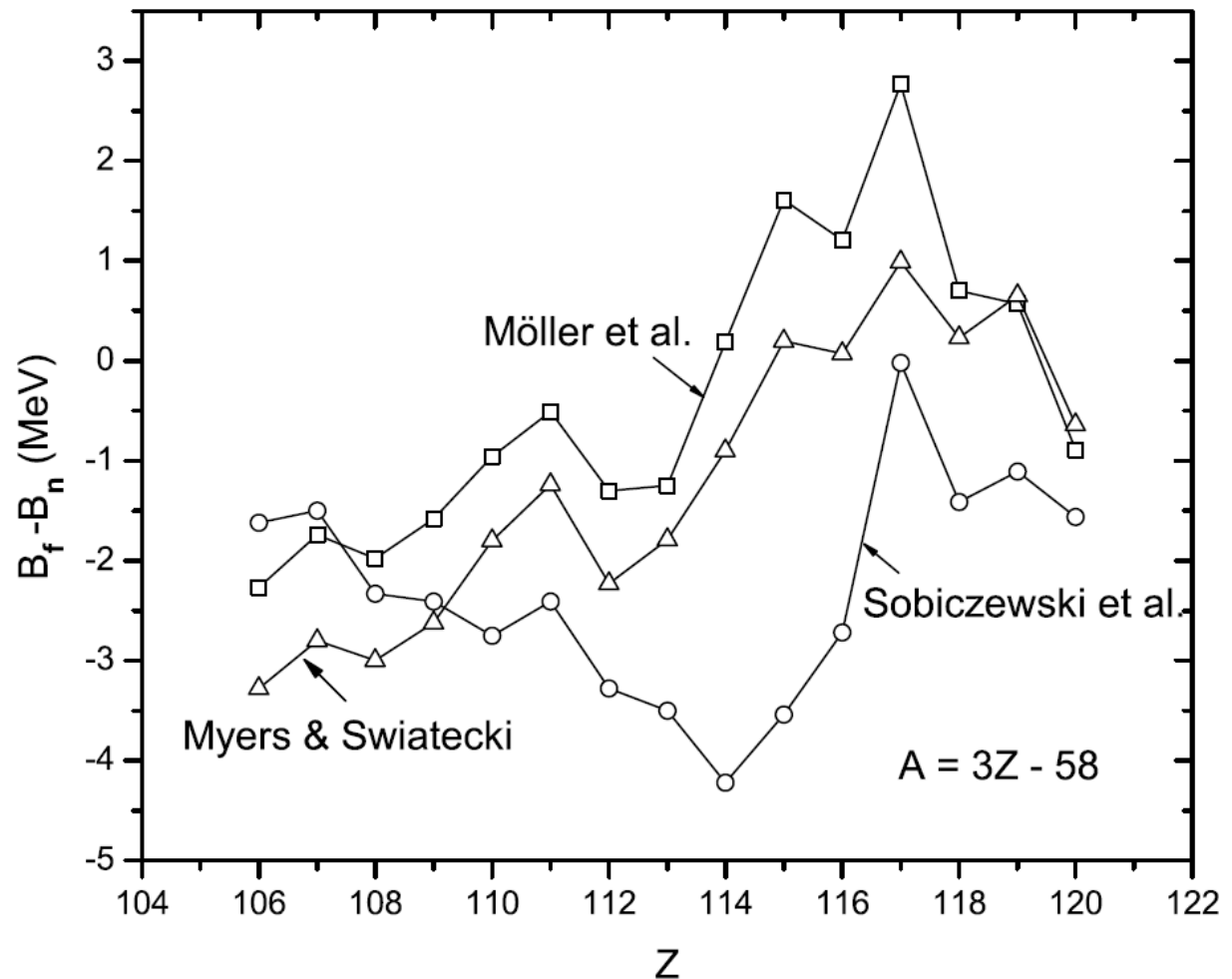



# The Future of New Elements

- A number of reactions have been studied:

- $^{50}\text{Ti} + ^{249}\text{Bk} \rightarrow ^{295}_{119} + 4n$
- $^{50}\text{Ti} + ^{249}\text{Cf} \rightarrow ^{295}_{120} + 4n$
- $^{54}\text{Cr} + ^{248}\text{Cm} \rightarrow ^{298}_{120} + 4n$
- $^{58}\text{Fe} + ^{244}\text{Pu} \rightarrow ^{298}_{120} + 4n$
- $^{64}\text{Ni} + ^{238}\text{U} \rightarrow ^{298}_{120} + 4n$

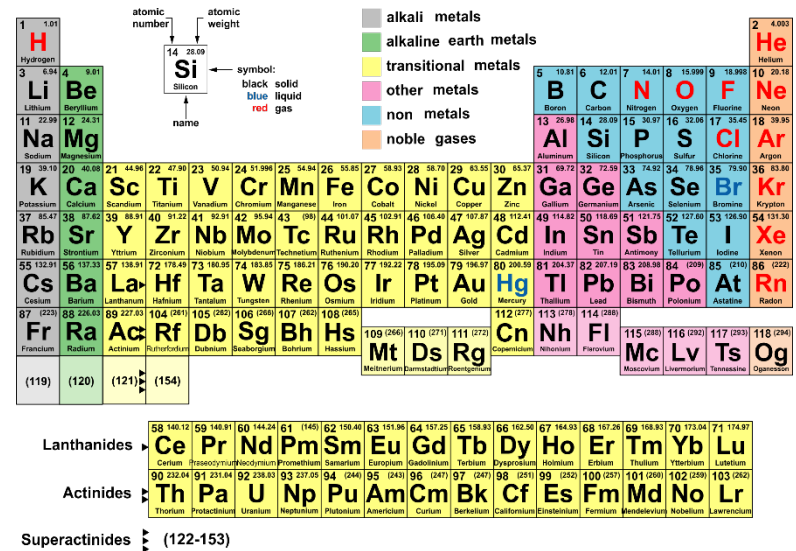

- Theoretical predictions generally indicate very low production rates for all of these reactions.
- None of these experiments have been successful.

# Prospects for the Discovery of the Next New Element

- Element discovery has progressed in groups.
- We may be in another period of few new elements.

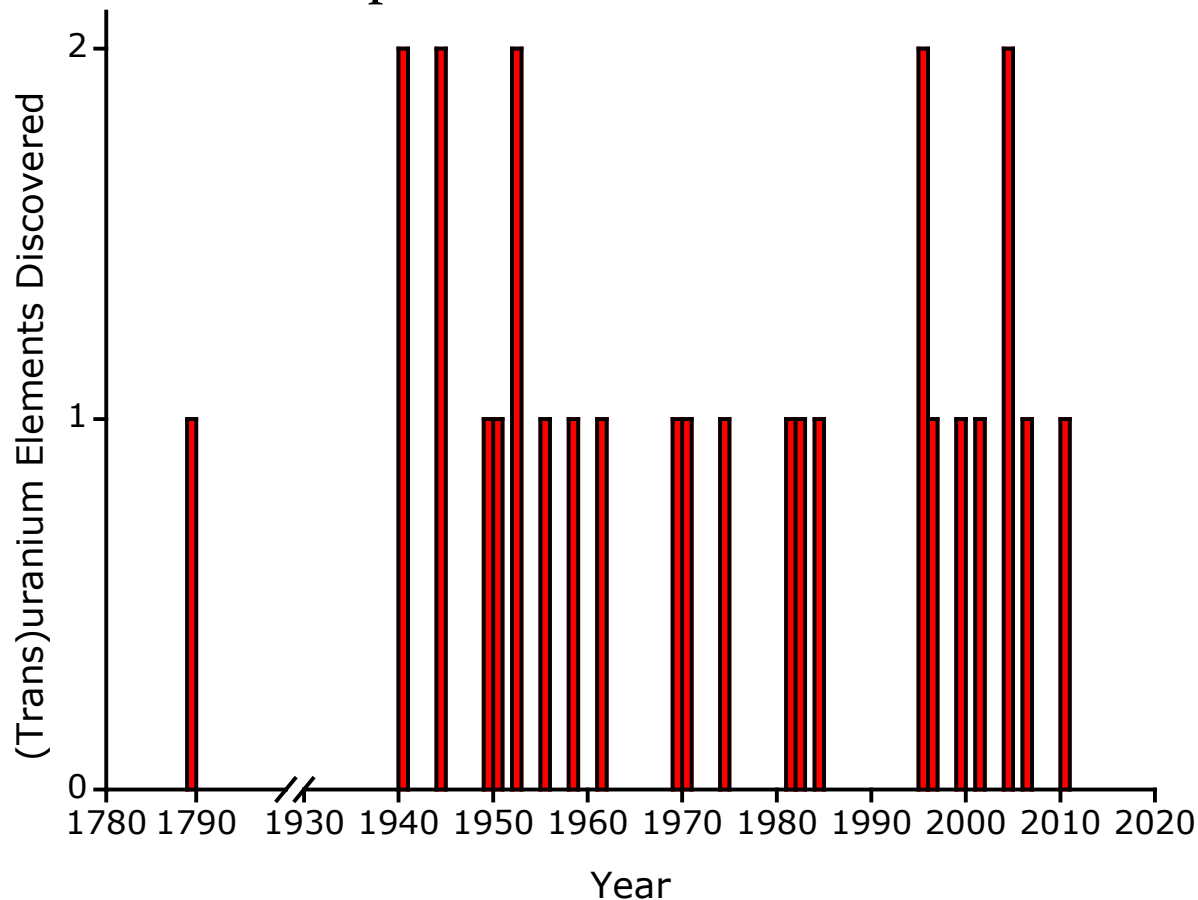

Adapted from a figure by D. C. Hoffman.

# Use of Exotic Beams for SHE Synthesis?

- Walt Loveland has thoroughly investigated the question of how RIBs can be used for heavy elements.

PHYSICAL REVIEW C **76**, 014612 (2007)

## **Synthesis of transactinide nuclei using radioactive beams**

W. Loveland

*Dept. of Chemistry, Oregon State University, Corvallis, Oregon 97331, USA*

(Received 19 March 2007; published 24 July 2007)

The prospects for the synthesis of transactinide nuclei using radioactive beams are evaluated quantitatively for a modern radioactive beam facility. A simple formalism for calculating the complete fusion cross sections that reproduces the known heavy element production cross sections over six orders of magnitude is used to calculate the production rates for transactinide nuclei with  $Z \leq 120$ . All possible projectile and target combinations are evaluated. Exciting new possibilities for studies of the atomic physics, chemistry, and nuclear spectroscopy of the heaviest elements should be realized at a modern radioactive beam facility. The synthesis of new heavy elements is best undertaken at stable beam accelerators.

# Production of Transactinide Nuclei Using Exotic Beams

- Access to longer-lived nuclides of transactinide elements would allow for more sophisticated expts.:
  - Wet chemistry, standard reduction potentials, etc.
  - Laser spectroscopy, ionization potentials, etc.

TABLE III. Long-lived neutron-rich nuclei produced by radioactive beam reactions with  $Z = 103-109$ .

Element	Heaviest known isotope produced directly	$t_{1/2}$	Predicted new isotopes and their predicted half-lives
Lr	262	216 min	(263, 12 h)(264, 80 d)(265, 196 d)
Rf	263	15 min	(264, 9.0 min)(265, 12.4 h)
Db	263	27 s	(264, 3.6 min)(265, 3.4 min)(266, 2.4 h)(267, 7.2 h) (268, 2.4 h)
Sg	266	21 s	(267, 4.2 min)(268, 7.1 min)(269, 1.3 min) (270, 2.6 s)
Bh	267	17 s	(268, 47 s)(269, 1.4 min)(270, 10.6 s)(271, 0.8 s)(272, 9.9 s)
Hs	270		(271, 0.13 s)(272, 0.02 s)(273, 0.13 s)(274, 0.83 s)
Mt	268	42 ms	(269, 6.4 ms)(270, 54 ms)(271, 69 ms)(272, 12 ms) (273, 1.2 ms)(274, 20.9 ms)(275, 78 ms)

# Economic Impact of Tennessee

- January 2017: A special edition of Jack Daniel's Single Barrel Select Whiskey “Element 117Ts Tennessee.”



Slide prepared by K. Rykaczewski.

# Popular Impact of Tennesseine



*The Big Bang Theory*, S9E15. Slide prepared by M. A. Stoyer.

# What has heavy element chemistry told us?

- The chemistry of the heaviest elements has been critical to our understanding of the periodic table.
- Glenn Seaborg developed the *actinide concept*, which places certain elements in a separate *actinide series*.

This is a black and white version of the periodic table from before World War II. It shows elements from Hydrogen (1) to Radium (88) and Actinium (89). The lanthanide and actinide series are not shown as separate rows but are indicated by arrows pointing to gaps in the main table. The elements are arranged in a standard periodic layout with atomic numbers and symbols.

Pre-World War II Periodic Table

This is a modern, color-coded periodic table. It includes elements up to Oganesson (118). A legend on the right side categorizes elements by color: alkali metals (green), alkaline earth metals (light green), transitional metals (yellow), other metals (orange), non metals (pink), and noble gases (light blue). A callout box for Silicon (Si) shows its atomic number (14), atomic weight (28.09), symbol, name, and physical state (solid, black).

This block shows the Lanthanide and Actinide series. The Lanthanides are listed from Cerium (58) to Lutetium (71). The Actinides are listed from Thorium (90) to Lawrencium (103). Below them, Superactinides are listed as (122-153).

Modern Periodic Table

# Standard Reduction Potential of $\text{No}^{3+}$

- The standard reduction potential of  $\text{No}^{3+}$ :

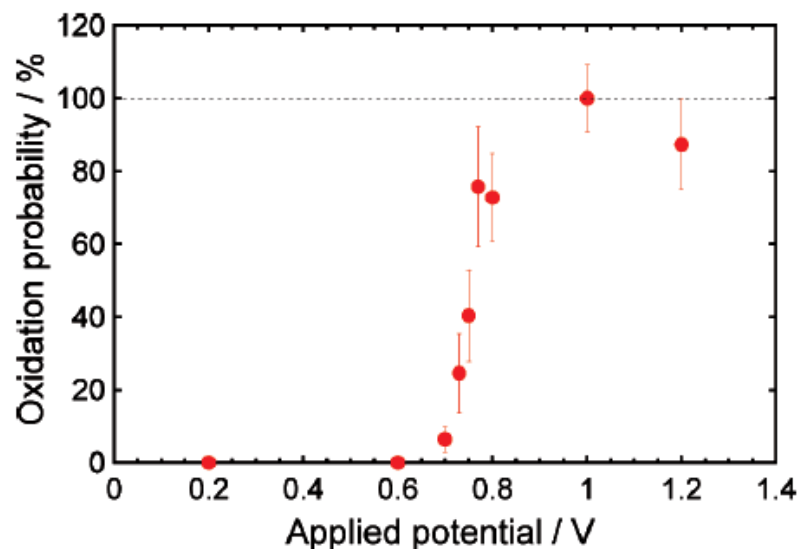
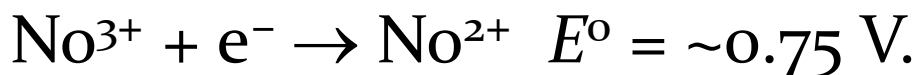

Figure 2. Oxidation probability of  $^{255}\text{No}$  vs applied potential.

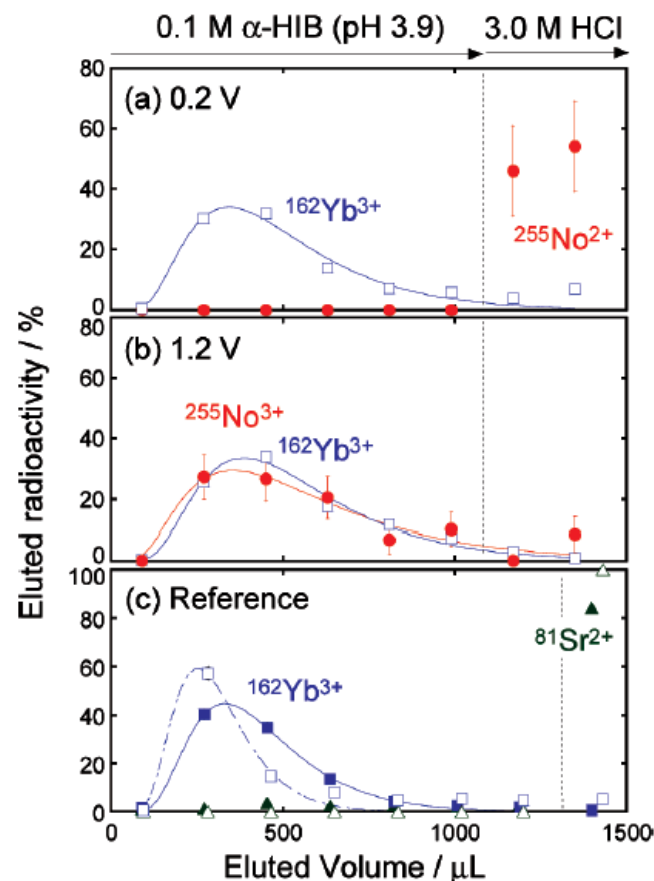
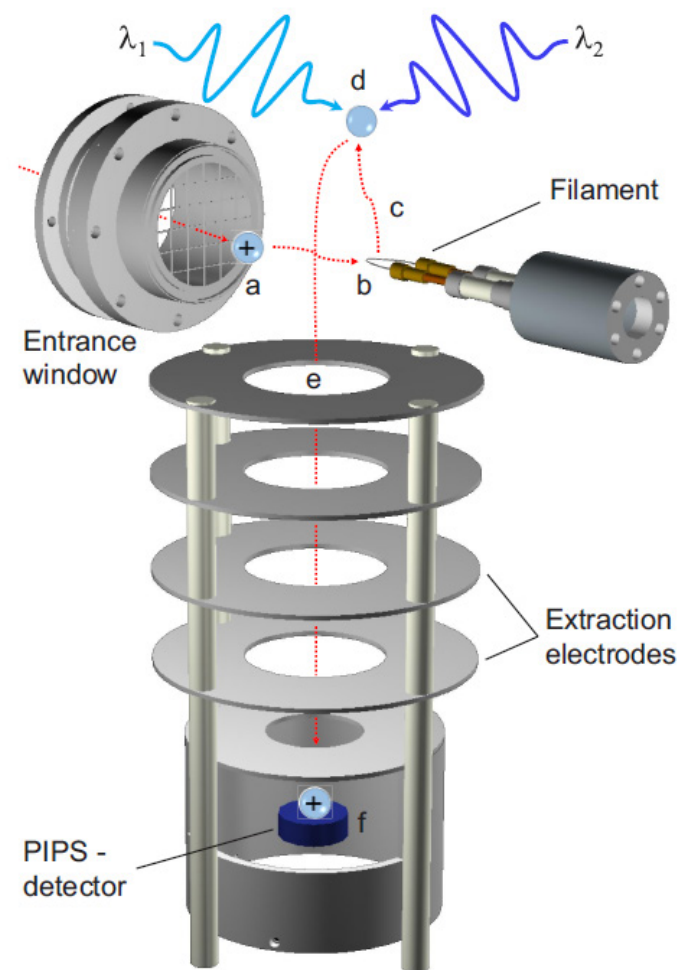
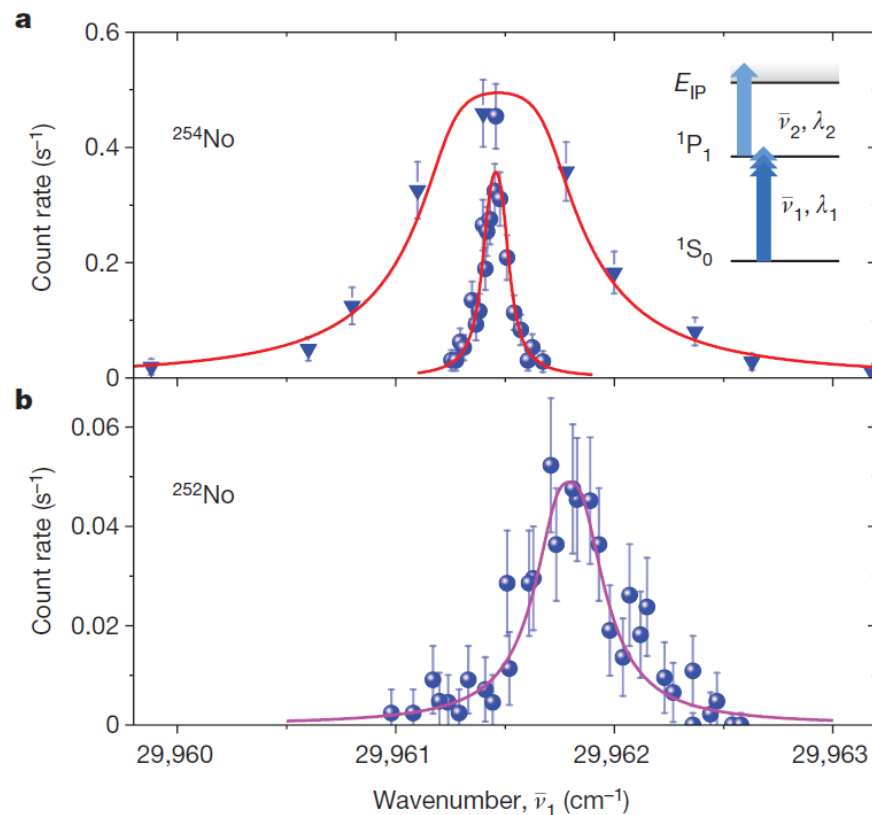

Figure 1. Elution behavior of  $^{255}\text{No}$  and  $^{162}\text{Yb}$  at applied potentials of (a) 0.2 and (b) 1.2 V. (c) Elution of the typical trivalent cation  $^{162}\text{Yb}^{3+}$  and divalent  $^{81}\text{Sr}^{2+}$  in the reference experiment, with solid symbols showing data at 0.2 V and open symbols data at 1.2 V.



# Laser Spectroscopy of No

- Resonance ionization measured  $^1S_0 \rightarrow ^1P_1$ .



# First Ionization Potential of Lr

- By measuring the yield through an “ionization cavity” and fitting to a calibration curve, the IP was determined.

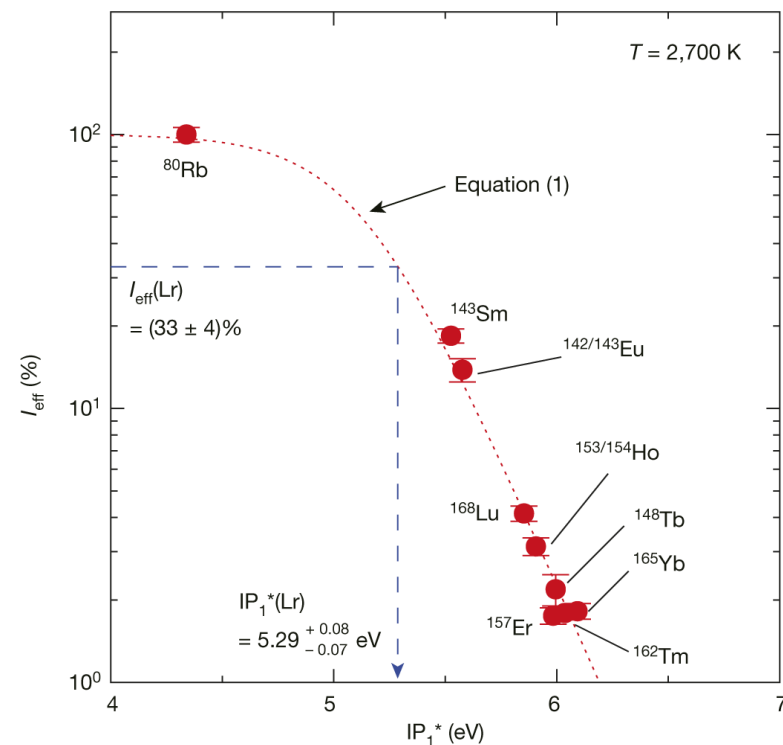
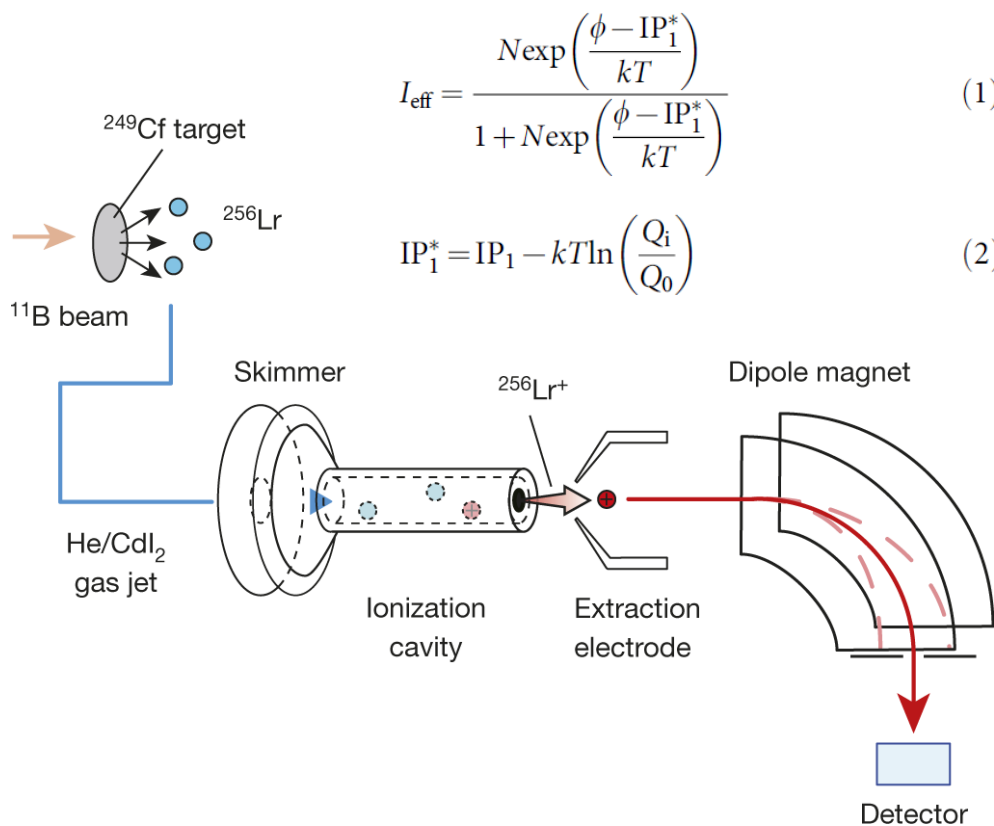

# Sg Carbonyl Complexes

- Sg is a homolog of Mo and W.
- A mixture of CO and He was used to form  $\text{Sg}(\text{CO})_6$ , similar to  $\text{W}(\text{CO})_6$ .

## Synthesis and detection of a seaborgium carbonyl complex

J. Even,<sup>1</sup> A. Yakushev,<sup>2</sup> Ch. E. Düllmann,<sup>1,2,3\*</sup> H. Haba,<sup>4</sup> M. Asai,<sup>5</sup> T. K. Sato,<sup>5</sup> H. Brand,<sup>2</sup> A. Di Nitto,<sup>3</sup> R. Eichler,<sup>6,7</sup> F. L. Fan,<sup>8</sup> W. Hartmann,<sup>2</sup> M. Huang,<sup>4</sup> E. Jäger,<sup>2</sup> D. Kaji,<sup>4</sup> J. Kanaya,<sup>4</sup> Y. Kaneya,<sup>5</sup> J. Khuyagbaatar,<sup>1</sup> B. Kindler,<sup>2</sup> J. V. Kratz,<sup>3</sup> J. Krier,<sup>2</sup> Y. Kudou,<sup>4</sup> N. Kurz,<sup>2</sup> B. Lommel,<sup>2</sup> S. Miyashita,<sup>5,9</sup> K. Morimoto,<sup>4</sup> K. Morita,<sup>4,10</sup> M. Murakami,<sup>4,11</sup> Y. Nagame,<sup>5</sup> H. Nitsche,<sup>12,13</sup> K. Ooe,<sup>11</sup> Z. Qin,<sup>8</sup> M. Schädel,<sup>5</sup> J. Steiner,<sup>2</sup> T. Sumita,<sup>4</sup> M. Takeyama,<sup>4</sup> K. Tanaka,<sup>4</sup> A. Toyoshima,<sup>5</sup> K. Tsukada,<sup>5</sup> A. Türler,<sup>6,7</sup> I. Usoltsev,<sup>6,7</sup> Y. Wakabayashi,<sup>4</sup> Y. Wang,<sup>8</sup> N. Wiehl,<sup>1,3</sup> S. Yamaki<sup>4,14</sup>

# Attempted Determination of SHE Atomic Number

- Two expts. have tried to observe x-rays in coincidence with  $\alpha$ .

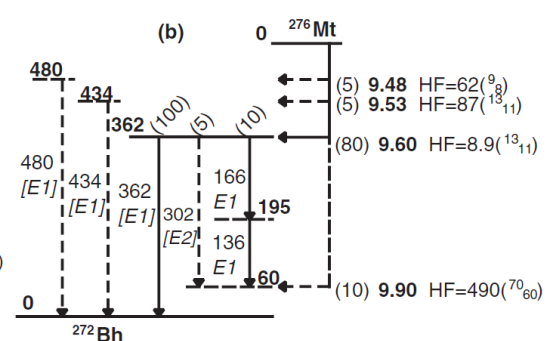
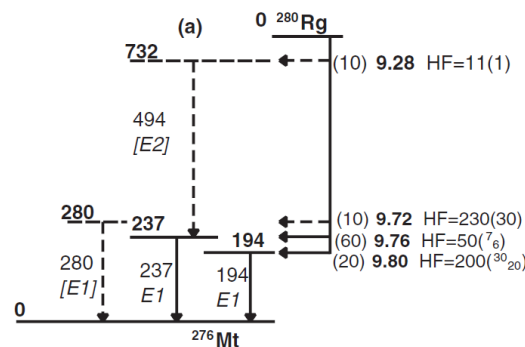
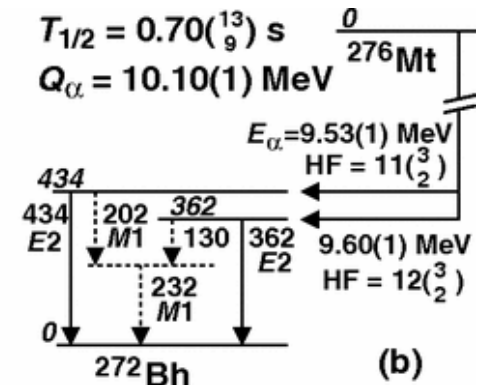
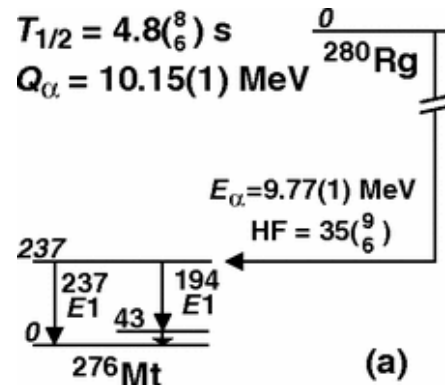
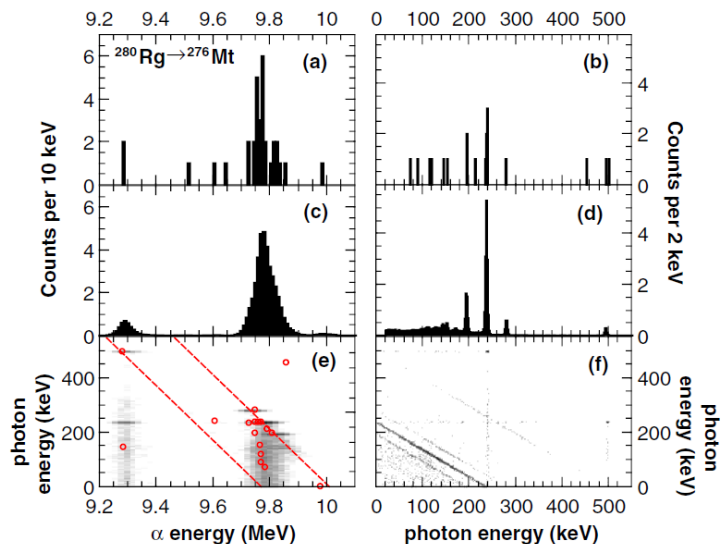

J. M. Gates *et al.*, Phys. Rev. C **92**, 021301(R) (2015). doi:[10.1103/PhysRevC.92.021301](https://doi.org/10.1103/PhysRevC.92.021301)

D. Rudolph *et al.*, Phys. Rev. Lett. **111**, 112502 (2013). doi:[10.1103/PhysRevLett.111.112502](https://doi.org/10.1103/PhysRevLett.111.112502)

D. Rudolph *et al.*, J. Radioanal. Nucl. Chem. **303**, 1185 (2015). doi:[10.1007/s10967-014-3445-y](https://doi.org/10.1007/s10967-014-3445-y)

# How does an atom-at-a-time chemistry experiment work?

- We want to compare some transactinide chemical property to that of its lighter homologs.
- We have billions and billions of atoms of a homolog available (remember that  $1 \text{ mol} = 6.022 \times 10^{23}$  atoms), but only a few of the transactinide for comparison.
- We have to be clever!
- Step 1: Use a nuclear reaction to make the transactinide.
- Step 2: Possibly use a chemical reaction to make a compound of this transactinide.
- Step 3: Measure the radioactive decay of the heavy atom.
- Use the data to extrapolate to macroscopic quantities.

# Hassium (Z = 108) Chemistry Experiment

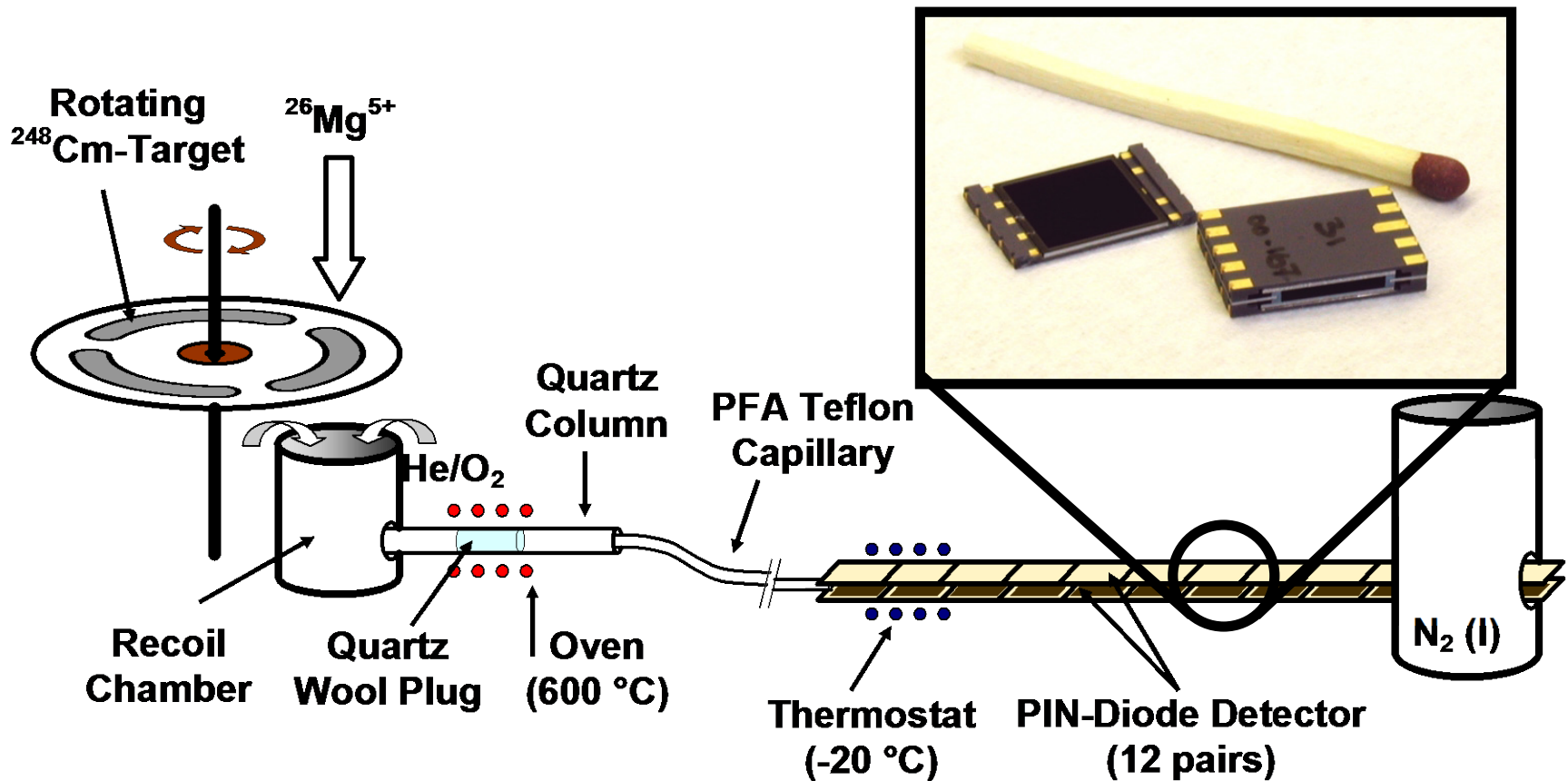
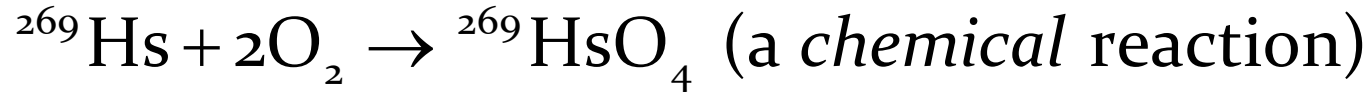
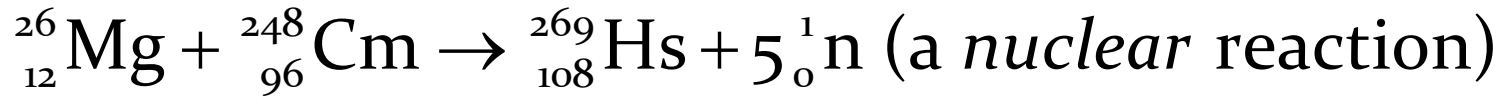

# Comparison with the Lighter Homolog Osmium

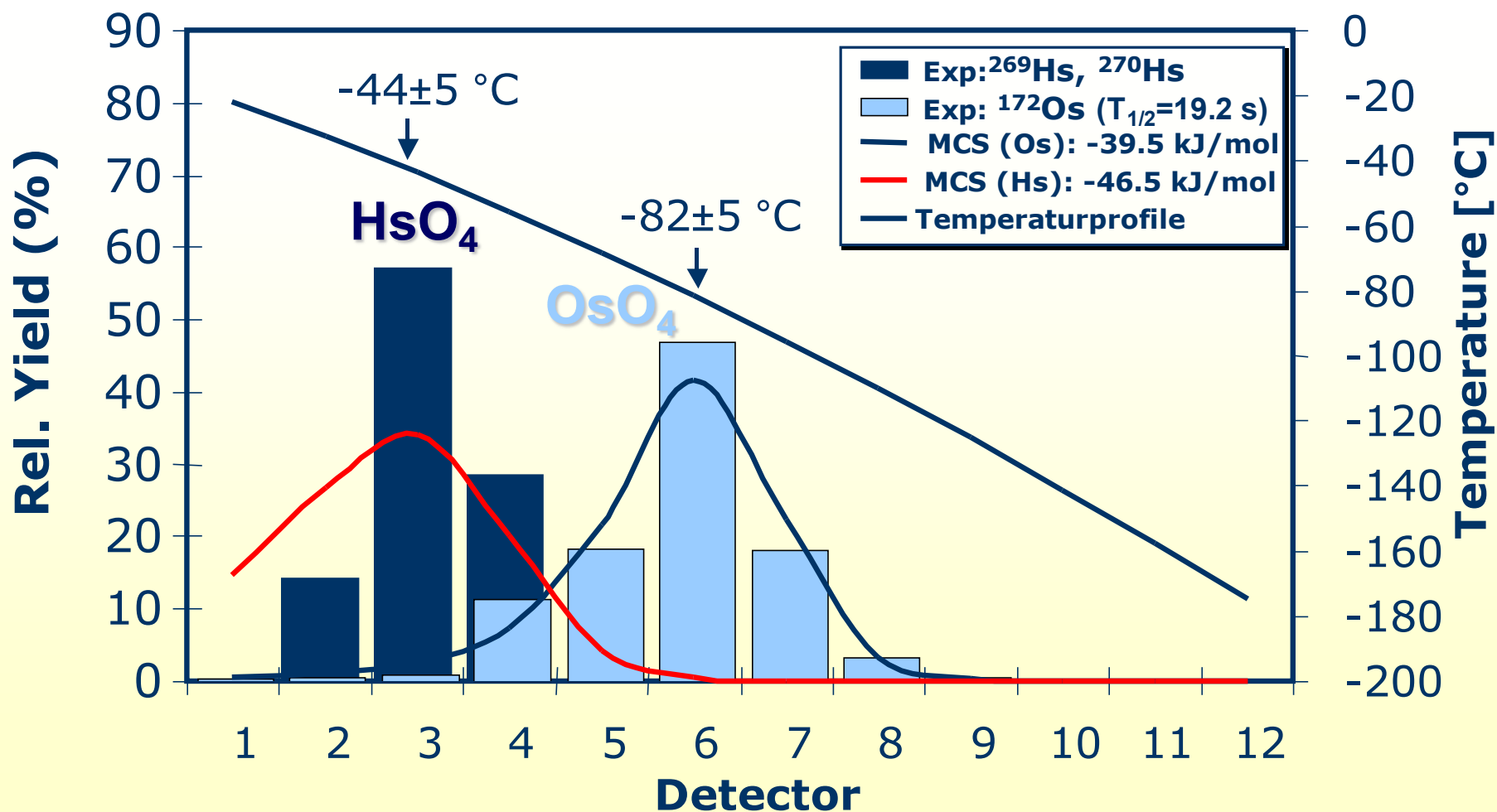

# Hs Simulation and Results

- Once you have the experimental data, you do a Monte Carlo simulation of the experiment that takes into account the geometry of the channel, the temperature profile, and the observed decay chains.
- The simulation tells you the *adsorption enthalpy* of the tetroxides on the detector surface ( $\text{Si}_4\text{N}_3$ ) that is most likely to give you the observed distribution.
- $\text{OsO}_4$ :  $\Delta H_{\text{ads}} = -39 \pm 1 \text{ kJ/mol}$
- $\text{HsO}_4$ :  $\Delta H_{\text{ads}} = -46 \pm 2 \text{ kJ/mol}$
- Notice that this experiment give you the energy *per mole*, even though there were only *seven* molecules.
- The element is placed on the periodic table!



# Relativistic Effects and Copernicium ( $Z = 112$ ) Chemistry

- The effect is that  $s$  and  $p$  orbitals are contracted and stabilized, while the  $d$  and  $f$  orbitals are expanded and destabilized.
- For Cn, this may mean that the filled  $6d^{10}$  shell may behave like the filled  $6s^2 6p^6$  orbitals of a noble gas.
- Does Cn behave chemically like the noble gas radon or like its periodic table homolog mercury?

Legend:

- alkali metals
- alkaline earth metals
- transitional metals
- other metals
- non metals
- noble gases

Modern Periodic Table

Atomic number: 112, Symbol: Cn, Name: Copernicium

Group: 18 (Noble Gases)

Period: 7

Block: s-block

Electron configuration:  $[Rn] 5f^{14} 6d^{10} 7s^2 7p^6$

Atomic weight: 285

Physical state: solid

Color: black

Modern Periodic Table

# Copernicium Chemistry Setup

- The *nuclear* reaction is  $^{48}\text{Ca} + ^{238}\text{U} \rightarrow ^{283}\text{Cn} + 3\text{n}$ .
- The reaction products are stopped in a mixture of He and Ar.
- They go through a purification step into a closed-loop system with minimal oxygen and water.
- The main component is a *thermochromatography column*.

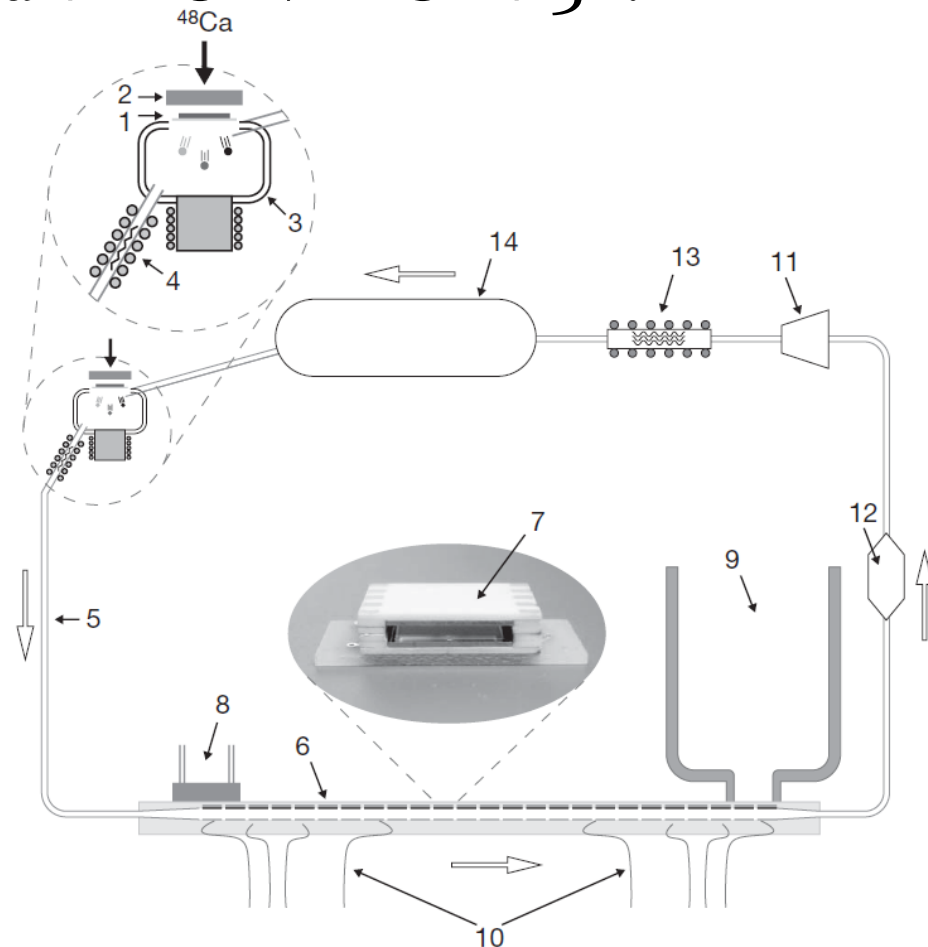

# Copernicium Chemistry Results

- The experiment was designed to produce Cn, Hg, and Rn at the same time.
- Hg is not volatile and deposits even at high temperatures.
- Rn is volatile and only deposits at low temperatures.
- Cn is somewhere in between.

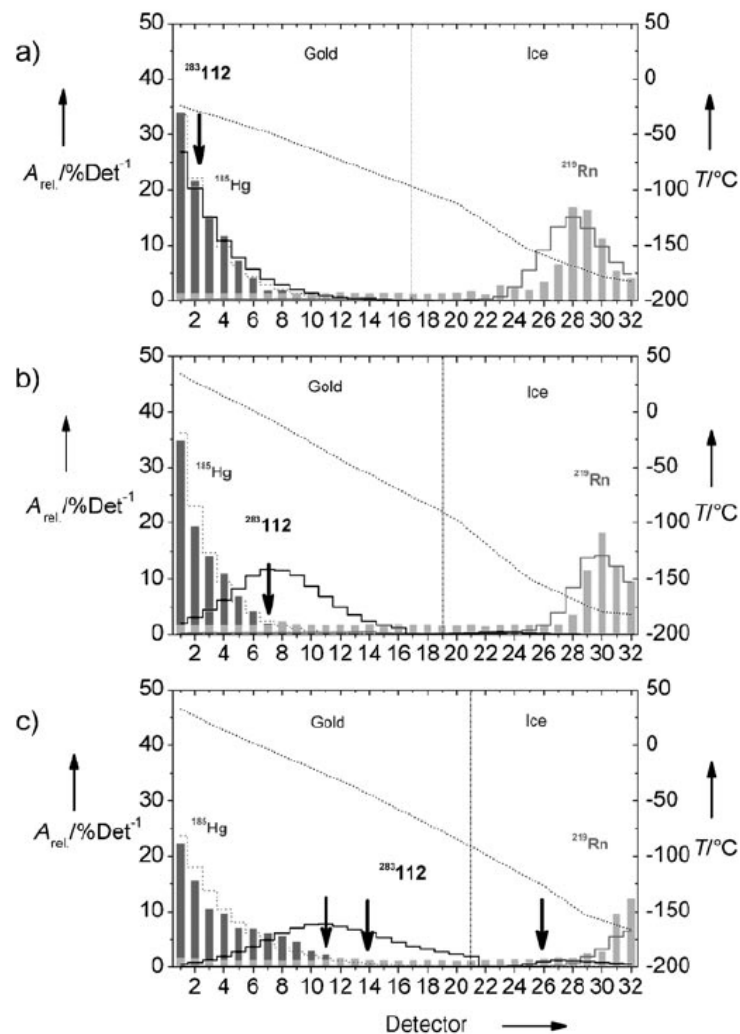

# Cn Simulation and Results

- Once you have the experimental data, you do a Monte Carlo simulation of the experiment that takes into account the geometry of the channel, the temperature profile, and the observed decay chains.
- The simulation tells you the *adsorption enthalpy* of the metal on the detector surface (Au) that is most likely to give you the observed distribution.
- Hg:  $\Delta H_{\text{ads}} = -98 \pm 3 \text{ kJ/mol}$                       Rn:  $-27 \pm 3 \text{ kJ/mol}$
- Cn:  $\Delta H_{\text{ads}} = -52 \pm 4 \text{ kJ/mol}$
- Notice that this experiment give you the energy *per mole*, even though there were only a few molecules.
- The element is placed on the periodic table!

# Pershina *et al.* Comments on Nihonium Adsorption on Au

Even though it is predicted to be chemically more inert than Tl, element 113 should rather well adsorb on the gold surface in the He/H<sub>2</sub> atmosphere with  $\Delta H_{\text{ads}}(113) = -158.6$  kJ/mol which requires very high  $T_{\text{ads}}$ . Since the gold plated silicon detectors in the gas-phase chromatography experiments cannot be heated above 35 °C, element 113 will adsorb right at the beginning of the chromatography column with a negative temperature gradient, being indistinguishable in this way from Tl. Thus, only a low limit of  $-\Delta H_{\text{ads}}$  can be given by such a thermochromatography study. In

# Dubna Nihonium ( $Z = 113$ ) Chemistry Experiment

- Dmitriev *et al.* reported a broad distribution of 113 on room-temperature Au surfaces with  $-\Delta H_{\text{ads}} > 60$  kJ/mol.

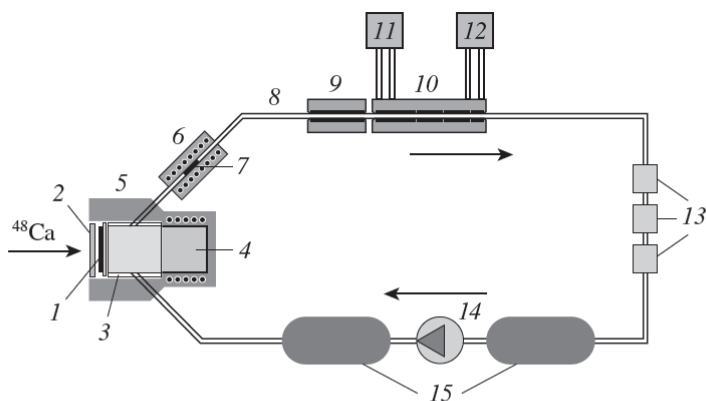

**Figure 1** Schematic diagram of the experimental setup for studying the chemical properties of element 113: (1)  $^{243}\text{Am}$  ( $1.5 \text{ mg cm}^{-2}$ ) +  $^{\text{nat}}\text{Nd}$  ( $15 \text{ } \mu\text{g cm}^{-2}$ ) target on the backing of Ti ( $2 \text{ } \mu\text{m}$ ); (2) vacuum window ( $4 \text{ } \mu\text{m}$  Ti foil); (3) cylindrical quartz insertion; (4) beam-stop with water cooling; (5) target chamber; (6) oven; (7) quartz filter; (8) transport capillary; (9) isothermal detector of 16 pairs of Au(Si) detectors at ambient temperature; (10) cryodetector of 32 pairs of Au(Si) detectors; warm end at  $+20^\circ\text{C}$  and cold end at  $-50^\circ\text{C}$ ; (11) water thermostat; (12) cryothermostat; (13) gas purification system; (14) pump; and (15) buffer volumes.

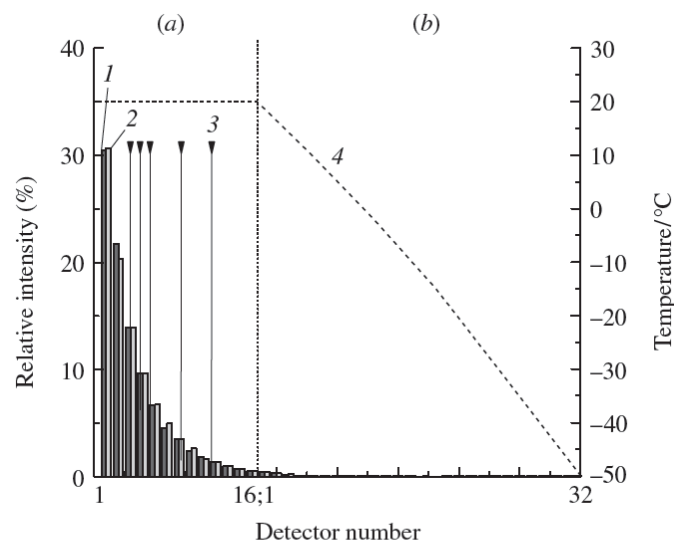

**Figure 3** Distribution of (1)  $^{185}\text{Hg}$  and (2)  $^{211}\text{At}$  in the detector modules together with (3) the position of the observed decay chains attributed to  $^{284}\text{113}$ ; dashed line (4) represents the temperature gradient from  $+20$  to  $-50^\circ\text{C}$  at (a) isothermal and (b) cryomodule of the detector.

# Flerovium ( $Z = 114$ ) Chemistry Results

- The experiment produced Fl, Pb, Hg, and Rn at the same time.
- Pb and Hg are *not* volatile and deposit even at high temperatures.
- Rn is volatile and only deposits at low temperatures.
- “Fl is a *volatile metal*, the least reactive one in group 14.” (emphasis in original).

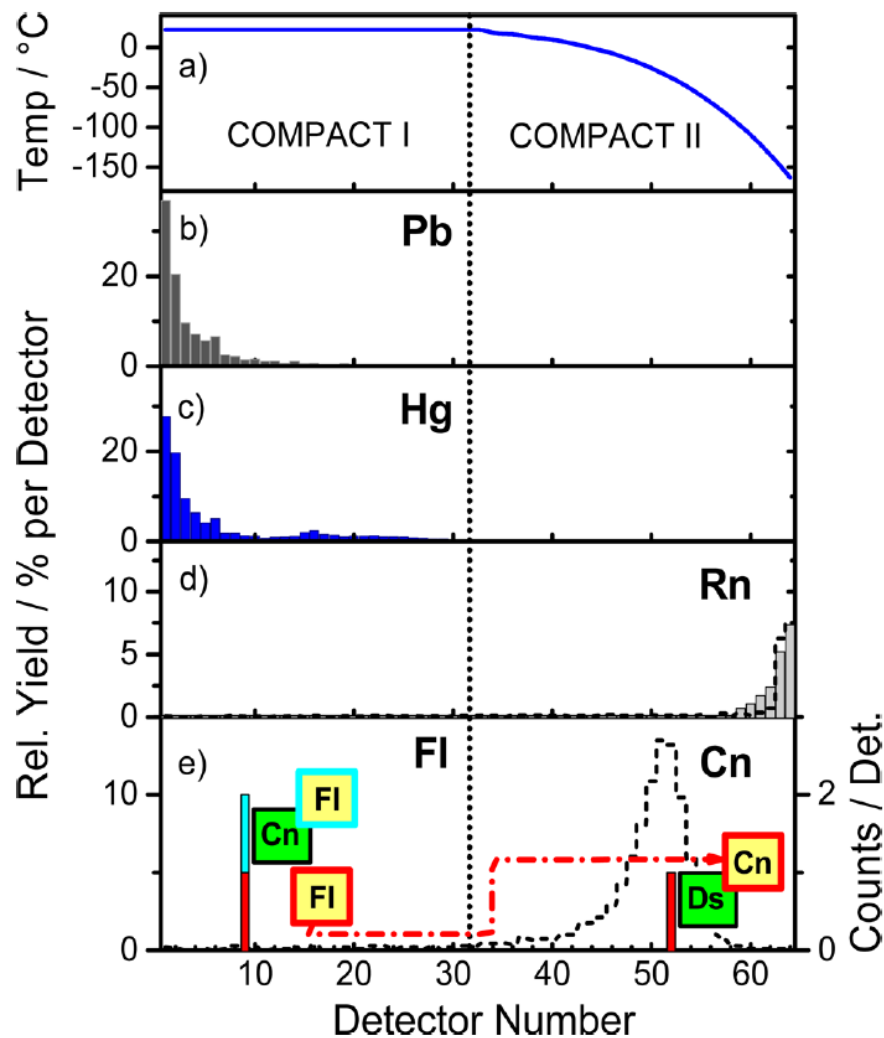

# Summary

- The study of heavy and superheavy elements has had a profound impact on our understanding of nuclei and the periodic table.
- There are currently 118 known elements. The pathway to the next new element is not clear.
- The role of exotic beams is limited to specialized cases.
- Chemical experiments are undergoing a renaissance:
  - First chemical studies of elements.
  - Organometallic chemistry.
  - Atomic spectroscopy.