

# GANIL OPERATION STATUS AND UPGRADE OF SPIRAL1

F. Chautard, O. Bajeat, P. Delahaye, M. Dubois, P. Jardin, O. Kamalou,  
L. Maunoury, G. Sénécal

GANIL, Grand Accélérateur National d'Ions Lourds, CEA-DSM/CNRS-IN2P3, Bvd H. Becquerel, BP  
55027 14076 Caen cedex 5, France

## Abstract

The GANIL facility (Caen, France) is dedicated to the acceleration of heavy ion beams for nuclear physics, atomic physics, radiobiology and material irradiation. The production of stable and radioactive ion beams for nuclear physics studies represents the main part of the activity. The exotic beams are produced by the Isotope Separation On-Line method with SPIRAL1 facility. It is running since 2001, producing and post-accelerating radioactive ion beams. The review of the operation from 2001 to 2011 is presented. Because of the physicist demands, the facility is about to be improved with the project Upgrade SPIRAL1. The goal of the project is to extend the range of post-accelerated exotic beams available. The upgrade of the “Système de Production d'Ions Radioactifs en Ligne” phase I (SPIRAL1) is in progress and should be ready by 2015.

- A high-energy beam out of CSS2 is transported to experimental areas (<95MeV/u).
- An auxiliary experiments shares the previous CSS2 beam (10% of the pilot experiment time)
- Finally, stable beams from SPIRAL1 source can be sent to LIRAT (<34keV/A) or post-accelerated by CIME and given to detector tests for example.

During radioactive beam production with SPIRAL1, the combination are reduced to the four first and with radioactive beam sent to the 2 last experimental areas mentioned.

## 2001-2009 GANIL OPERATION STATUS

Since 2001 (Figure 2), more than 38280 hours of beam time has been delivered by GANIL to physics. A third of this time is given to SPIRAL1. The total beam time for physics (tuning and maintenance excluded) is on the average around 3400 hours a year.

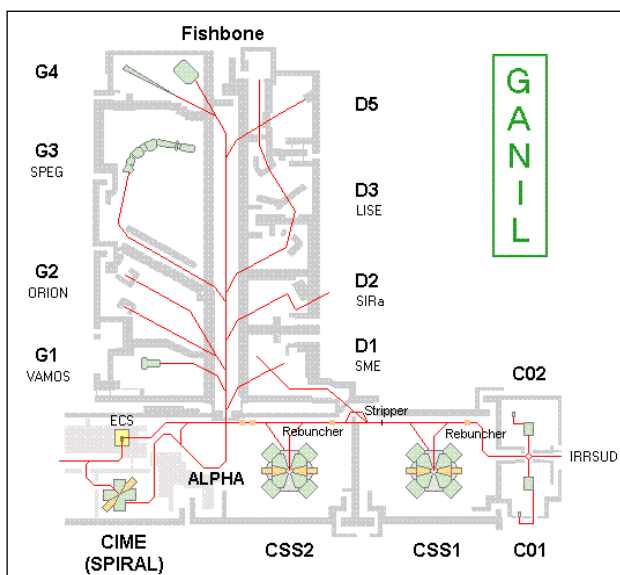

Figure 1: GANIL layout.

## OPERATION REVIEW

Multi-beam delivery is routinely done at GANIL using its 5 existing cyclotrons. Up to five experiments can be ran simultaneously in different rooms with stable beams (Figure 1):

- Beams from C01 or C02 are sent to an irradiation beam line IRRSUD (<1MeV/u).
- A charge state of the ion distribution after the ion stripping downstream CSS1 is sent to atomic physics, biology and solid states physics line D1 (4-13MeV/u).

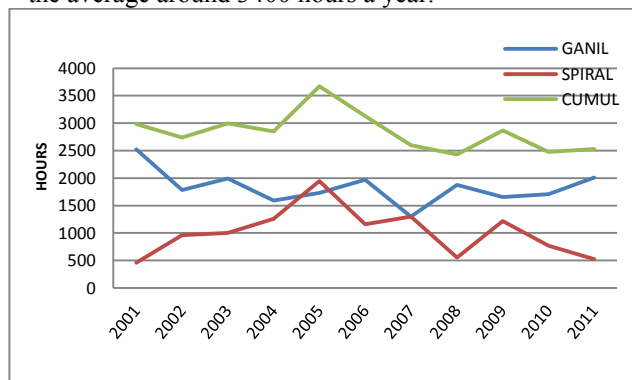

Figure 2: Beam time repartition between SPIRAL and GANIL beams over 11 years.

The number of beam delivered per year (Figure 3) has increased until 2010. Owing to the arrival of SPIRAL2, the running time has been reduced to devote more ressources to the project.

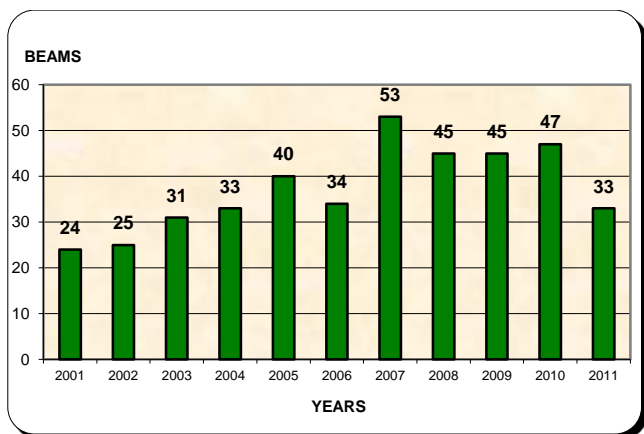

Figure 3: Number of beams tuned between 2001 and 2011.

Figure 4 shows such maintenance actions have given rise to higher time availability.

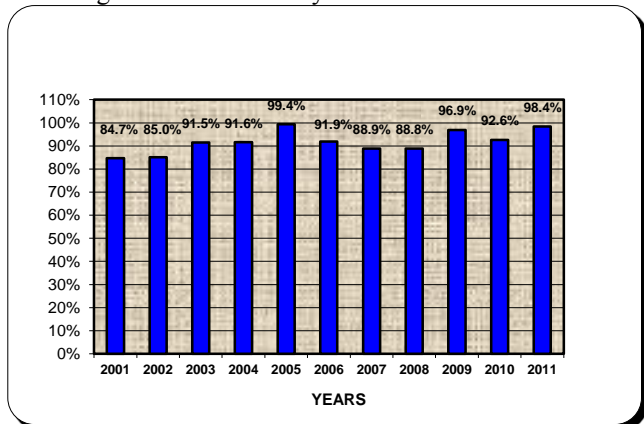

Figure 4: Ratio of beam time available for physics to scheduled beam time online.

### UPGRADE SPIRAL1

The first Isotope Separator On Line System installed at GANIL, named SPIRAL1, has delivered radioactive ions for 10 years. Radioactive atoms produced by fragmentation of swift heavy ions (up to 95 MeV/u) on a carbon target are ionized in a multi-charged ECR ion source before being post-accelerated in a cyclotron. Owing to the design of the target ion source system (TISS), mainly gaseous ions are produced. To satisfy the request of physics community in extending the choice of ions to those made from condensable elements, with masses up to Xe an upgrade of SPIRAL1 has been undertaken. Beams and technical options considered during the prospective phase have been sorted out. A schematic of the ongoing upgrade is presented Figure 5. Surface ionization, FEBIAD or ECR ion sources will be installed in the production cave after its modification to provide 1+ beams of condensable elements. Out of the cave and after mass separation, a Phoenix type charge booster will be installed on the present low energy beam line to

increase the charge of the radioactive ions from 1+ to N+ for post-acceleration.

The upgrade of SPIRAL1 and its technical environment need to conform to stringent regulation requirements as explained below.

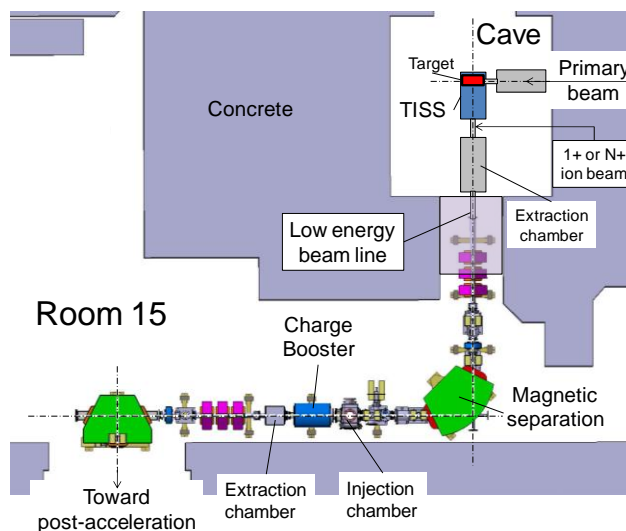

Figure 5: Schematic of the SPIRAL1 upgrade.

### NEW BEAMS VERSUS NEW TISS

New elements will be mainly produced by fragmentation of primary beam ions on a graphite target. Thus most of the masses and atomic numbers will generally not be higher than those of the primary beams available at GANIL. The elements to be produced can be divided in three groups:

1- alkali elements and rare earth elements (Li, Na, K, Rb and Sr). The elements will be ionized in an existing TISS already tested on line at GANIL on a test bench.

2- metallic ions (Mg, Al, Ca, Sc, Cr, Mn, Co, Ni, Cu, Zn, Ga, Ge, As and Se). They will be produced by association of a carbon target with a FEBIAD of VADIS type developed at CERN (Figure 6). This association has been recently tested on line with primary beams of  $^{58}\text{Ni}$  (intensity up to 270 nA) and of  $^{36}\text{Ar}$  (intensity up to 77 nA).  $^{23}\text{Mg}^+$ ,  $^{25}\text{Al}^+$ ,  $^{33}\text{Cl}^+$ ,  $^{38}\text{K}^+$ ,  $^{58}\text{Mn}^+$ ,  $^{58-60}\text{Cu}^+$  and  $^{53-53m}\text{Fe}^+$  ions have been produced. Preliminary estimates give intensities of  $6.6 \times 10^4$  and  $1.4 \times 10^4$  pps for  $^{53}\text{Fe}$  and  $^{53m}\text{Fe}$  respectively for  $^{58}\text{Ni}$  at 72 MeV/u. They indicate good performances for the TISS as Fe beams were only recently observed at ISOLDE. A forthcoming article should describe these tests in detail. The technical design is being pursued, mainly for improving the setup reliability. The final version should be ready in 2013.

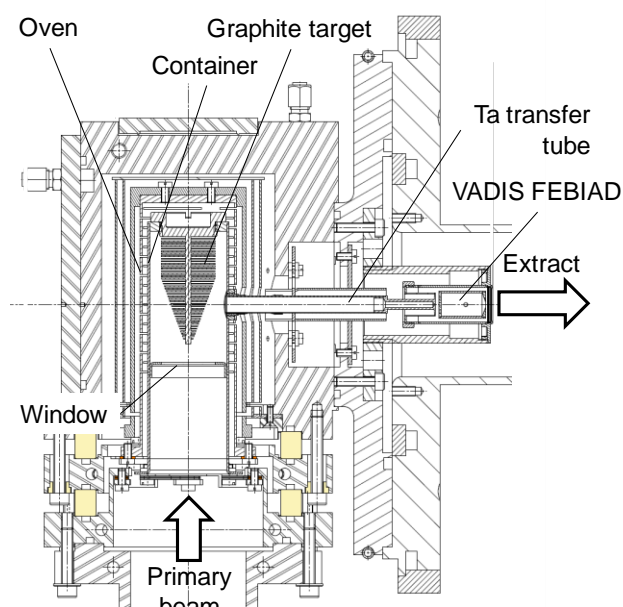

Figure 6: TISS made by association of a graphite target with a VADIS FEBIAD ion source.

3- non-metallic ions, halogen and rare gas ions (He, Ne, Ar, Kr, O, C, P, Cl and Br). Multi-charged ions from rare gases, C and O are currently produced using the ECR ion source of SPIRAL1.

Because the singly-charged ion sources are shorter than the present NANOGAN III ECRIS along the low energy beam line axis, a chamber containing optical elements will be installed in place of it to adapt the 1+ beams to the present low energy beam line.

Some elements heavier than the projectiles will be produced by fusion-evaporation reactions, at lower beam energies. Using heavier target material than graphite will also be possible and beneficial in a 2<sup>nd</sup> step. As an example, to produce  $^{62,63}\text{Ga}$  isotopes, the reaction  $3.6 \text{ kW } ^{12}\text{C} (95 \text{ MeV/u}) + \text{Nb}$  leads to gain a factor of six on the yields compared to  $1.2 \text{ kW } ^{78}\text{Kr} (70 \text{ MeV/u}) + \text{C}$  reaction.

### CAVE UPGRADE

Ten years after delivering its first radioactive ion beam, the cave of SPIRAL1 must be modified to accommodate the new TISSs. Up to now, multi-charged radioactive ions could be directly produced in the cave for post acceleration. After the modification, it will also be possible to produce singly charged ions in the cave, which will be charge bred in a booster after mass separation. The main advantages are a higher purity of the beam of interest owing to a pre-separation of the singly charged ions in the first magnetic dipole and production of higher charge states which will allow heavier elements to be injected in the post accelerator (cyclotron) and thus higher final energy.

The upgrade of the cave attempts to fulfill simultaneously the two following conditions: minimizing the transformation of the cave and of its

environment (building, handling systems, safety protections and process, cooling system, nuclear ventilation system etc...) while increasing its flexibility in terms of useable TISS. The modification of the cave will start during the second semester of 2012. In the course of 2013, the cave should be able to accept both the former and new TISSs.

### CHARGE BOOSTER

An important part of the upgrade consists in the installation of the charge booster on the low energy beam line (room 15), after the mass separator. The booster that will be used at SPIRAL1 is a commercial version of the Phoenix booster designed by LPSC, GRENOBLE, and constructed by Pantechnik. It has been tested at CERN and then at TRIUMF. Moreover, the same principle has been successfully tested at ANL. The possibility to make the 1+ and existing N+ beams going through the booster when it is off has been taken into account. This function is essential when the beam delivered by the TISS is directly used, *i.e.* without charge breeding, either for post-acceleration or in the experimental beam line LIRAT (Ligne d'Ions Radioactifs A Très basse énergie).

The singly charged ions coming from the cave will cover the range from  $\text{He}^+$  to  $\text{Xe}^+$ , with post-accelerated energies ranging from  $\sim 25 \text{ MeV/u}$  to  $\sim 7 \text{ MeV/u}$  respectively, depending on the isotopes considered. The breeding efficiency is generally better for ion masses higher than  $\sim 30$ . Beyond mass higher than  $\sim 100$ , the transport between the TISS and the booster must be made at lower extraction voltage, due to the limit of the magnetic rigidity of the mass separator, which limits the transport efficiency. Thus the preferential mass range of SPIRAL1 upgrade goes from  $\sim 30$  to  $\sim 100$ .

The booster has been recently shipped from CERN to GANIL. The optical study is done. The design of the booster has been consolidated in particular with UHV components, double RF injection, and a position-tunable injection tube. The design of mechanical supports and injection/extraction chambers is underway, as is the supplying of services (power supplies, RF emitter). The installation of the booster will be achieved by end of 2014.

New singly-charged radioactive ion beams are expected by 2013, and multi-charged ion beams by 2015.