

HIGH POWER TEST OF A 57-MHz CW RFQ*

P.N. Ostroumov, A. Barcikowski, B. Clift, B. Rusthoven, S. Sharma,
 S.I. Sharamentov, W. F. Toter, ANL, Argonne, IL 60439, U.S.A.
 J.W. Rathke, Advanced Energy Systems, Medford, NY 11763, U.S.A.
 N.E. Vinogradov, Northern Illinois University, De Kalb, IL, USA
 D.L. Schrage, TechSource, Santa Fe, NM, U.S.A.

Abstract

High power heavy-ion drivers require a CW low-frequency RFQ for initial acceleration. The low frequency specifications required for heavy-ion acceleration typically result in large dimensions of the structure. By appropriate choice of the resonant structure for the Rare Isotope Accelerator (RIA) driver RFQ we have achieved moderate transverse dimensions of the cavity and high quality accelerating-focusing fields required for simultaneous acceleration of multiple-charge-state ion beams. In our application the RFQ must provide stable operation over a wide range of RF power levels to allow acceleration of masses from protons up to uranium. To demonstrate the technology and high-power operation we have built an engineering prototype of one-segment of the 57-MHz RFQ structure. The RFQ is designed as a 100% OFE copper structure and fabricated with a two-step furnace brazing process. The errors in the tip-to-tip distances of the vanes average less than 50 microns. The RF measurements show excellent electrical properties of the resonator with a measured intrinsic Q equal to 94% of the simulated value. In this paper we report final results of high-power tests.

INTRODUCTION

A Continuous Wave (CW) Radio Frequency Quadrupole (RFQ) accelerator has been designed for the RIA Driver Linac [1] and reported previously [2]. The basic parameters of the RIA driver RFQ are listed in Table 1. The resonator is a pseudo split coaxial structure as shown in Fig. 1 [2]. Preliminary engineering design of the resonant cavity has been discussed in ref. [3,4]. The cavity is designed as a 100% OFE copper structure and fabrication is based on a two-step furnace brazing process. The cavity consists of six nearly identical longitudinal segments. We have built an engineering prototype of one-segment of the RFQ structure for the following purposes: a) to develop a fabrication technology to satisfy the RFQ cavity specifications; b) to define an inter-vane voltage limit; c) to demonstrate stable operation in wide dynamic range of RF power and d) to compare simulation results with the experiment and guide the choice of appropriate simulation tools for the design of a full-scale RFQ.

Figure 2 shows an exploded view of the one-segment engineering model.

* This work was supported by the U.S. Department of Energy under Contracts No. W-31-109-ENG-38.

#ostroumov@phy.anl.gov

Table 1: Basic parameters of the RIA driver RFQ

	Parameter	Value
1	Duty cycle	100% (CW)
2	Operating frequency	57.5 MHz
3	Frequency of the nearest mode	68.4 MHz
4	Vane length	392 cm
5	Design inter-vane voltage	68.5 kV
6	Peak surface field	140 kV/cm
7	Average radius	0.6 cm
8	Input beta	0.00507
9	Charge-to-mass ratio	$\geq 28.5/238$
10	Power dynamic range	70:1

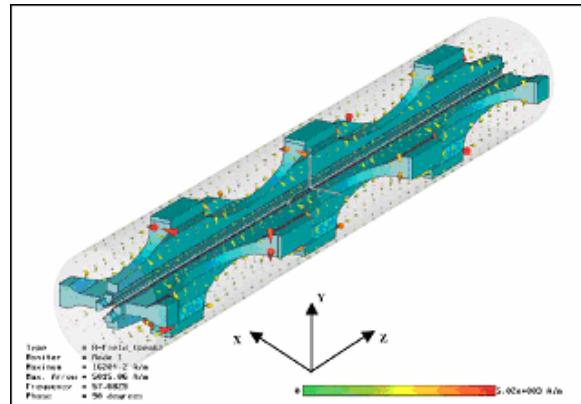

Figure 1: Microwave Studio (MWS) Plot of Magnetic Fields in the Pseudo Split Coaxial RFQ Structure [1].

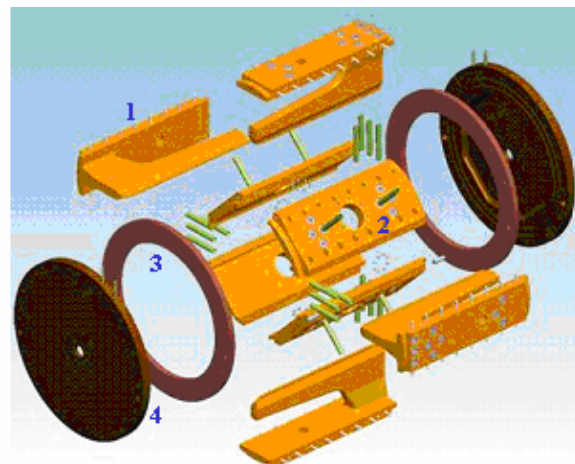

Figure 2: Exploded view of the one-segment RFQ assembly. 1. Vanes; 2. Quadrant plates; 3. Main flanges; 4. End caps.

FABRICATION

Several different approaches to fabrication of the RIA RFQ were discussed during the conceptual design phase. Ultimately we chose a fully-brazed assembly using step brazing to fabricate the vanes and quadrant details and finally a complete segment with end flanges. This approach borrows heavily from the techniques used successfully on the LEDA RFQ at Los Alamos [5].

The RFQ is designed as a 100% OFE copper structure including flanges and end caps. The fabrication process includes the following main stages:

- Delivery of raw copper. Blister tests, test brazing of water plugs and vane-quadrant connection.
- Preliminary machining of vanes, quadrants, end caps (see Fig. 2), drilling water cooling channels and performing a high temperature furnace brazing of water channel plugs using 35-65 Au-Cu alloy, in a hydrogen atmosphere.
- Final machining of all parts including vane tip modulation and cleaning in heated Citranox bath.
- Fabrication of the fixture which is suitable for assembly of the cavity, lifting, transportation and preparation of the cavity for final assembly brazing. Fabrication of the cavity support fixture to be used in the furnace.
- Assembly of the cavity and pre-brazed machining to install end flanges. Preparation to load into the furnace in vertical orientation.
- Final brazing using CuSil alloy in a hydrogen retort atmosphere furnace.
- Post-brazing machining to match end caps.
- RF measurements and final cleaning of the cavity assembly in heated Citranox bath.
- Assembly of water-cooling channels, installation of the cavity on support frame, installation of water-cooled tuners, pick-up loops, driving loop, RF transmission line and vacuum system.

Figure 3 shows the pre-brazing assembly of the cavity prior to machining to match the end flanges. Caliper and CMM measurements of the tip-to-tip distances of the vane on both ends of the cavity have been performed at various stages of the manufacture process. Final CMM measurements showed that the vane tip positions are within 50 μm of the design values.

Figure 4 shows the final assembly of the cavity before the connection of the RF transmission line. We designed a water-cooled coupling loop with a ceramic cylinder vacuum window as shown in Fig. 5. The coupling loop has been fabricated using electron-beam welding and high-temperature furnace brazing.

VACUUM AND LOW POWER TESTS

The RFQ cavity is equipped with three water-cooled tuners. The tuners, driving loop, and two pick-up loops and end caps are sealed with O-rings for vacuum and Bal-Seal springs for RF contacts. The cavity was designed four years ago using an early version of the MWS

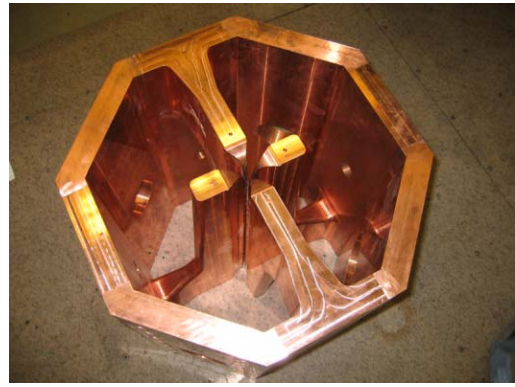

Figure 3: Top view of the pre-brazed assembly of the cavity.

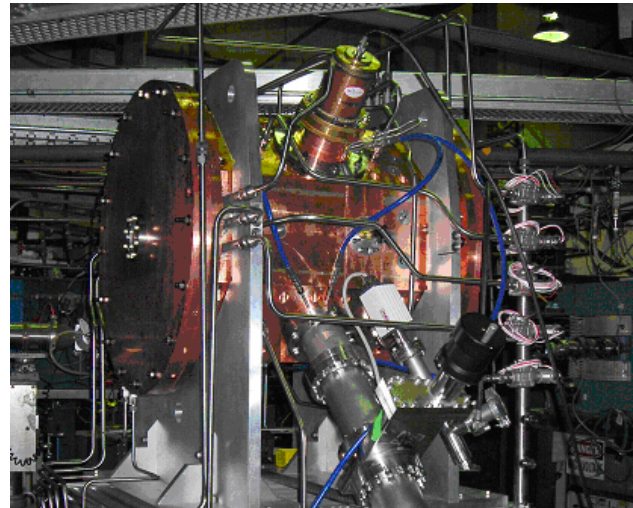

Figure 4: General view of the RFQ.

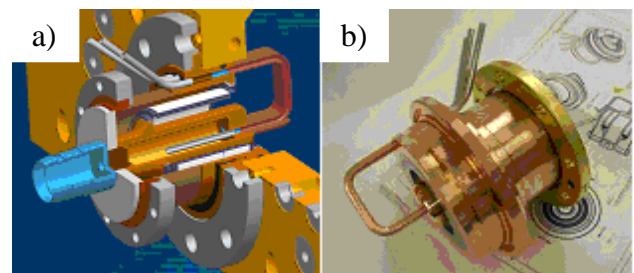

Figure 5: Water-cooled coupling loop: a) 3D cut-out view and b) brazed unit.

software. Although the design goal was 57.0 MHz with no tuners inserted, the measured frequency is 55.863 MHz. However, the latest versions of both HFSS and MWS predict the right frequency, as shown in Table 2. The frequency discrepancy is of no consequence for testing purposes. To avoid possible reduction of the cavity Q-factor it was decided to use short tuners without penetration into the cavity volume and operate the cavity at the lower frequency of 55.86 MHz. The intrinsic Q, measured just after the cleaning in Citranox bath without tuners installed, was 8860 which is 95% of the simulated

value. After installation of the tuners, the cavity was exposed to nitrogen and air for several short periods during 3 months. The resulting cavity Q is slightly lower, as can be seen in Table 2.

The cavity vacuum is maintained by a 345 L/sec turbo pump and dry scroll pump. The vacuum in the cavity has stabilized at $1.8 \cdot 10^{-7}$ Torr in several days.

HIGH-POWER TESTS

The high-power tests were performed using a triode amplifier procured from industry. After several hours outgassing, the inter-vane voltage was increased to 75 kV, limited by the amplifier power. To increase available power, the triode circuit was tuned to the cavity frequency to produce 22 kW into a dummy load. When full RF power was applied, the cavity was operated with vacuum in the medium 10^{-6} Torr range. Due to the restricted capacity of the cooling system, the cavity can be operated at high power level only in self-excited mode. The eigenfrequency of the cavity drops to 55.465 MHz at the highest available power and the cavity temperature increases by 20°C.

Inter-vane voltage calibration was performed by two methods: a) using power-loss measurements and b) X-ray end-point energy measurements. The power loss through the driving to pick-up loops was measured by an HP Network Analyzer and it was equal to 47.57 dB. The pick-up loop power was measured directly by a power meter.

For a cavity operating at high power levels, the X-ray end point method provides a non invasive and precise technique for measuring inter-electrode voltage [6]. The corresponding spectrum originates from the electrons present in the cavity due to field emission. The highest energy achieved by the electrons is eV, where V is the maximum voltage between the electrodes. A XR-100CR detector with a built-in pre-amplifier made by AMPTEC Inc. was used for the measurements of X-ray spectra. The preamplifier output was fed into an amplifier and then to the multi-channel analyzer (MCA) connected to the PC. X-rays were registered through the glass window and 1/16" or 1/8" lead shield along the z-axis of the cavity. A typical X-ray spectrum corresponding to the highest voltage achieved in the RFQ cavity is shown in Figure 6. So far no sparking has been observed in the cavity when the available RF power is limited by the amplifier.

Table 2 shows the calculated and measured cavity parameters. Simulations by HFSS and MWS have been performed using exact 3D model of the cavity. The cavity power was measured on a calibrated pick-up loop while the voltage corresponded to the maximum X-ray energy. We observed multipacting in the cavity at 200-230 Watts power level. This level of RF power corresponds to the voltage required for acceleration of protons when the design voltage for the uranium beam is 68.5 kV. Our experiments suggest that the design voltage for uranium beam can be chosen to be at least ~85 kV, which makes

the RF power required for proton acceleration equal to 320 W. We can therefore conclude that the RFQ cavity will provide stable acceleration of any ions, from hydrogen to uranium.

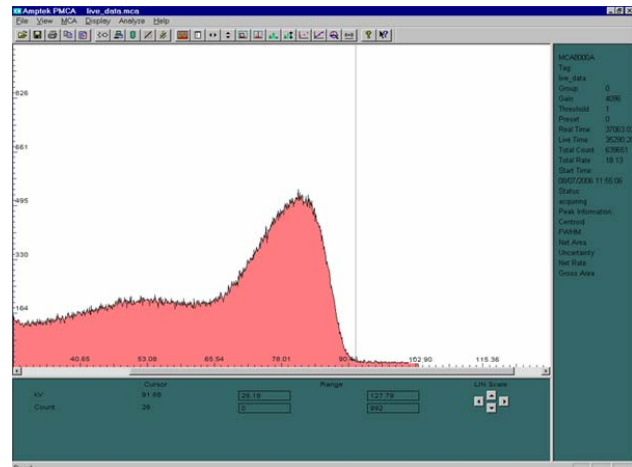

Figure 6: X-ray spectrum corresponding to the 91.5 kV inter-vane voltage.

Table 2: Comparison of the simulated and measured parameters of the one-segment RFQ cavity.

Parameter	Simul.	Meas.
Frequency, MHz	55.62	55.863
Quality factor	9317	8688
Stored energy ($V_0=68.5$ kV), J	0.254	-
P (kW) to obtain $V_0=68.5$ kV, kW	9.5	10.2
P (kW) to obtain $V_0=91.5$ kV, kW	17.6	19.0

CONCLUSION

The basic design concepts, namely, 100% OFE copper structure machined prior to the assembly with high accuracy, and brazing in high temperature hydrogen atmosphere furnace have proven extremely successful, as evidenced by the voltages achieved and RF power requirements in initial tests of the RIA driver RFQ. So far no sparking has been observed in the cavity when operating up to the limit of available RFQ power.

ACKNOWLEDGEMENT

We thank Drs A.A. Kolomiets (ITEP, Moscow) and G. Waldschmidt (ANL) for providing simulations by the HFSS and MWS codes.

REFERENCES

- [1] J.A. Nolen, "Overview of the RIA Project," Nuclear Physics A734 (2004), p. 661-668.
- [2] P. Ostroumov, et al, PRST-AB, 5, 060101 (2002).
- [3] J.W. Rathke, et al, LINAC'02, Gyeongju, Korea, p. 467.
- [4] T. Schultheiss, et al, LINAC'02, Gyeongju, Korea, p. 470.
- [5] D. Schrage, et al., LINAC'98, Chicago, IL, p. 679.
- [6] J. Brutscher, Institut fur Angewandte physik, GSI-Report 88-17, 1988.